



**ANNOVI
REVERBERI**®
The Power of Experience



– CATALOGO **CLEANING** –
DIVISION *CATALOGUE*

INDICE INDEX

IDROPULITRICI LINEA HOME&GARDEN P 5

Home&Garden line High pressure washers

Applicazioni Applications	P 5
EASY	P 6
2LT	P 7
2K X-TRA	P 9
DHS 2KA	P 11
4K TWIN FLOW	P 13
5K TWIN FLOW	P 14
4LT	P 15
5LT	P 15
AQUASWEEPER	P 16
Accessori Accessories	P 18

IDROPULITRICI LINEA PROFESSIONAL P 22

Professional line High pressure washers

PRO COLD	P 22
Applicazioni Applications	P 22
5SP	P 23
SPARK	P 24
VIP REVO	P 25
VIP REVO KART	P 26
BLITZ	P 28
RS	P 32
MODENA	P 35
10 SERIES	P 36
SUPREME	P 44
Accessori Accessories	P 52

PRO HOT P 60

Applicazioni Applications	P 60
HOT 1507 - 1608	P 61
HOT 1608 PRO	P 62
HOT 1510	P 63
HOT 1815	P 64
HOT 1815N - 2315	P 65
HOT 2321N	P 66
HOT INOX	P 67

Accessori Accessories P 69

ASPIRACENERE ED ASPIRATORI P 73

Ash & Vacuum Cleaners

HOME	P 74
WD 15	P 75
WD 25	P 76
WD 30X	P 77
WD 35T	P 78
WD 50XT	P 79
AR20M	P 80
PRO	P 81
WD 76/2	P 82
WD 76/3	P 83
Accessori speciali Special accessories	P 84
Accessori Accessories	P 86

POMPE AUTOADESCANTI SENZA E CON AUTOCLAVE P 90

Self-priming pumps without and with booster unit

PG3100P	P 91
PG4600X	P 92
PG3100PB	P 93

POMPE AD IMMERSIONE P 94

Submersible pumps

PS6000PC	P 95
PS11000XC	P 96
PS13000PT	P 97
PS16500XD	P 99

Accessori Accessories P 100

LOGISTIC DATA P 102

CATALOGUE SIMBOLS INDEX P 106



ANNOVI ®
REVERBERI
The Power of Experience



**ANNOVI
REVERBERI**
The Power of Experience

Oltre 60 anni di esperienza e innovazione

Un supermercato di Parigi, un autolavaggio di Los Angeles, un campo di grano di Kiev: un'unica cosa in comune, un prodotto che deriva dal cuore dell'Italia, una pompa Annovi Reverberi. Fondata nel 1958 da Corrado Reverberi, Annovi Reverberi è ancora oggi un'azienda italiana di famiglia, una realtà metalmeccanica fortemente legata al territorio, fatta di persone idee e progetti innovativi. Un esempio di imprenditoria italiana basata su esperienza, artigianalità e innovazione. Un marchio riconosciuto in tutto il mondo come simbolo di massima qualità e saper fare italiano. Oltre 60 anni di storia che hanno visto il gruppo Annovi Reverberi crescere notevolmente e diventare protagonista in tre settori di riferimento: agricoltura con la produzione di pompe a membrana; industria attraverso il successo delle pompe a pistoni AR e infine intorno agli anni '90 cleaning con lo sviluppo di idropulitrici e aspiratori.

A supermarket in Paris, a car wash in Los Angeles, a wheat field south of Kiev: the same thing in common; a product from the heart of Italy, an Annovi Reverberi pump. Founded in 1958 by Corrado Reverberi, Annovi Reverberi is still an Italian family-owned company, a mechanical engineering reality strongly linked to the territory and made up of people, ideas and innovative projects. An example of Italian entrepreneurship based on experience, innovation and passion. A brand recognized all over the world as a symbol of top quality and Italian know-how. It's a 60 year history that has seen the Annovi Reverberi group grow significantly and become a protagonist in three sectors of reference: agriculture with the production of diaphragm pumps; industry through the success of AR piston pumps and, finally, around the 90s, cleaning with the development of high-pressure washers and vacuum cleaners.

CLEANING DIVISION

All'interno del mondo Annovi Reverberi particolare rilievo è da dedicare alla Divisione Cleaning, con i suoi molteplici marchi e le prestigiose licenze. Una divisione che anno dopo anno è riuscita a crescere, a consolidarsi ed a produrre idropulitrici sempre al passo coi tempi e soprattutto con le esigenze del mercato.

Grazie ad un marketing strategico, al know-how acquisito dalla parte tecnica e ad una gestione accurata e puntuale della produzione, la Divisione Cleaning ha saputo cogliere e superare le trasformazioni e i mutamenti del mercato, proponendo soluzioni sempre al passo coi tempi e sempre con la qualità che contraddistingue il marchio di fabbrica AR.

Nata a Modena

Born in Modena

The Cleaning Division, with its many brands and prestige licences, is particularly important within the Annovi Reverberi world. Over the years, this division has successfully grown, consolidated, and built high pressure washers constantly up-to-date with the latest developments and, above all, the market's demands.

Through strategic marketing, the know-how acquired by the technical side and thorough, accurate production management, the Cleaning Division has been quick to identify and respond to the market's transformations and changes, offering solutions that are always in line with the times, with all the AR brand's outstanding quality.



CASA & GIARDINO

Home & Garden

HOME & GARDEN APPLICATIONS



cancellate
fencing



panchine
benches



giardino
garden



biciclette
bicycles



moto
motorcycle



auto
cars



camper
recreational
vehicles RV's,
campers



barche
boats



pavimenti
flooring,
paving
stones



scale
stairs



piscine
pools



utensili
tools



casa
house

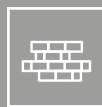

muri
walls



tetti
roofs



gardening
gardening



disinfestazione zanzare
pest control



igienizzazione superfici
sanitizing

Le idropulitrici della gamma Home & Garden sono la soluzione perfetta per la pulizia degli spazi domestici ed esterni. Queste idropulitrici dimezzano i tempi di pulizia, rendendo il lavoro semplice e di facile esecuzione, grazie anche ad un'ampia selezione di accessori studiata per i diversi campi di applicazione. Ne è un esempio il patio con serbatoio detergente incorporato, ideale per la pulizia di ampie superfici quali terrazze e bordi piscina, che ottiene risultati uniformi e brillanti alla prima passata! Le potenti lance con getto rotopower, opportunamente regolate di pressione, assicurano invece il miglior risultato sull'arredo da esterno, che costantemente esposto alle intemperie è spesso aggredito da sporco ostinato, con un semplice gesto.

Home & Garden range high pressure washers are the perfect solution for cleaning spaces inside and outside the home. These high pressure washers halve cleaning times, making the whole process simple and easy - thanks also to a wide range of accessories designed for the various fields of use. One example is the patio version, with integral detergent tank, ideal for cleaning large areas such as patios and swimming pool surrounds, which provides gleaming, uniform results in a single pass! In another application, the powerful lances with rotopower jet at the appropriate pressure setting ensure the best results on outdoor furniture, which is constantly exposed to the weather and often accumulates stubborn dirt, with the greatest of ease.



EASY

IDROPULTRICI ALTA PRESSIONE high pressure washer



Caratteristiche Generali

- Pompa a 3 pistoni assiali comandati dal piattello oscillante, testa in alluminio
- Pistoni in acciaio inox temperato
- Valvola di sicurezza automatica con azzeramento della pressione nella testa pompa
- Protezione termica del motore
- Ugello rotante
- Serbatoio detergente
- Funzione autoadescante
- Tubo alta pressione 5 m

General Features

- 3 Axial stainless steel pistons wobble-plate pump with aluminium head
- Tempered stainless steel pistons
- Automatic by-pass valve with pump head pressure discharge
- Motor thermal protector
- Rotary nozzle
- Detergent tank
- Self-priming function
- High pressure hose

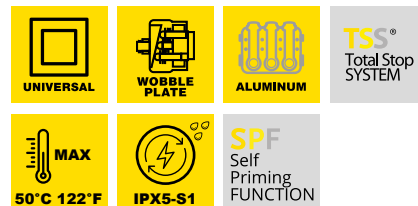

MOD	COD									
		MAX	MAX		NET					
		bar	psi	l/h	gph	kW	rpm	Hz	V	kg
EASY	14299	110	1600	370	98	1,4	3400	50-60	220-240~	6,7



Accessori standard Standard accessories



2LT

IDROPULITRICI ALTA PRESSIONE
high pressure washer



Caratteristiche Generali

- Carrello a 2 ruote completo di manico
- Pompa a 3 pistoni assiali comandati dal piattello oscillante, testa alluminio
- Pistoni in acciaio inox temperato
- Valvola di sicurezza automatica con azzeramento della pressione nella testa pompa
- Protezione termica del motore
- Tubo alta flessibilità (6 m)
- Ugello rotante
- Serbatoio detergente
- Funzione autoadescante

General Features

- *Two-wheel trolley with handle*
- *3 Axial stainless steel pistons wobble-plate pump with aluminium head*
- *Tempered stainless steel pistons*
- *Automatic by-pass valve with pump head pressure discharge*
- *Motor thermal protector*
- *Super flexible hose (6 m)*
- *Rotary nozzle*
- *Detergent tank*
- *Self-priming function*

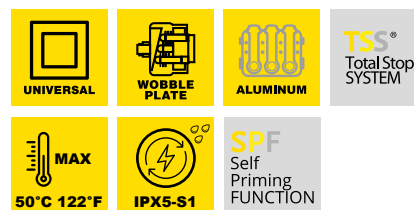

MOD	COD	MAX	MAX		NET				
		bar	psi	l/h	gph	kW	Hz	V	kg
2LT	15548	150	2175	420	110	1,9	50-60	220-240~	7

Accessori standard
Standard accessories



4381485 4381495 4821170



4381500 4100800 4381830





Sistema a doppia velocità.

Dual speed system.

Tramite il POWER SWITCH è possibile selezionare le modalità **ECO SPEED WASHING** e **MAX SPEED WASHING** e modulare il livello di performance dell'idropulitrice adeguandolo ad esigenze di pulizia più leggera, con un notevole risparmio di acqua e di energia (fino al 30%), o più intense in funzione del lavoro da svolgere.

*Using the POWER SWITCH it is possible to select the **ECO SPEED WASHING** and **MAX SPEED WASHING** modes, to modulate the performance level of the pressure washer, adapting it to lighter cleaning needs, with a considerable saving of water and energy (up to 30%), or more intense depending on the work to be done.*

30% ENERGY SAVING



ECO SPEED 30% ENERGY SAVING



Attivando la modalità **ECO SPEED** puoi dedicarti alla pulizia di sporco non aggressivo su superfici esterne in legno, biciclette, mobili da giardino in legno, tessuti esterni, con un **consumo energetico ottimizzato** e un miglior compromesso tra efficacia del lavaggio/consumi.

*By activating **ECO SPEED** mode you can dedicate yourself to cleaning non-aggressive dirt on external wooden surfaces, bicycles, wooden garden furniture, external fabrics, with **optimized energy consumption** and a better compromise between washing / consumption effectiveness.*

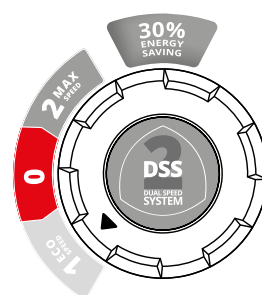

MAX SPEED FULL PERFORMANCE



Attivando la modalità **MAX SPEED** puoi dedicarti invece alla pulizia di sporco aggressivo su pietra, cemento e mattoni, ringhiere e cancelli in metallo, attrezzi da lavoro e da giardinaggio, automezzi con un **consumo energetico standard**.

*By activating **MAX SPEED** mode you can dedicate yourself to cleaning aggressive dirt on stone, concrete and bricks, metal railings and gates, work and gardening tools, vehicles) with **standard energy consumption**.*

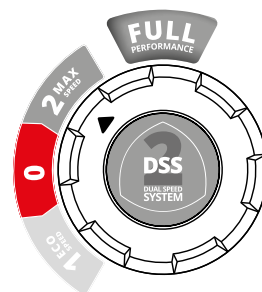

2K X-TRA

IDROPULITRICI ALTA PRESSIONE high pressure washer



schiumogeno alta pressione
high pressure foam lance



dispositivo click -fast
click-fast connection drive



avvolgitubo statico con tubo alta
flessibilità 6 m
static hose reel with super flexible
hose 6 m



selettore rotativo a 3 posizioni
off/Eco Speed/Full Speed
3 positions rotative switch
off/Eco Speed/Full Speed



battistrada in gomma
rubber wheels



Caratteristiche Generali

- Carrello a 2 ruote completo di manico
- Pompa a 3 pistoni assiali comandati dal piattello oscillante, testa alluminio
- Pistoni in acciaio inox temperato
- Valvola di sicurezza automatica con azzeramento della pressione nella testa pompa
- Sistema di arresto totale dell' idropulitrice a distanza
- Protezione termica del motore
- Filtro acqua ispezionabile
- Ugello rotante
- Lavasuperfici Ø250 mm
- Tubo alta flessibilità 6 m
- Funzione autoadescante

General Features

- Two-wheel trolley with handle
- 3 Axial stainless steel pistons wobble-plate pump with aluminium head
- Tempered stainless steel pistons
- Automatic by-pass valve with pump head pressure discharge
- Remote control for total shut-down of high pressure washer
- Motor thermal protector
- Inspectable water filter
- Rotary nozzle
- Surface cleaner Ø250 mm
- Super flexible hose (6 m)
- Self-priming function

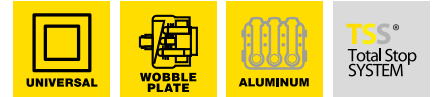

MOD	COD	MAX	MAX							KG NET
		bar	psi	l/h	gph	kW	rpm	Hz	V	kg
2K X-TRA	14992	160	2300	460	122	2,2	3400	50-60	220-240~	10,3

Accessori standard Standard accessories





Doppia azione, Doppia efficacia

Dual function, Dual efficiency.



Attivando **I Spraying Mode** si potrà utilizzare la lancia per nebulizzazione prodotti che andranno preventivamente inseriti nel serbatoio. Particolarmente adatta per igienizzare, sanificare, e prelavare superfici e forniture esterne. Ideale per disinfezione zanzare e applicazioni gardening.

*Activate **I Spraying Mode** to sanitize, pre-wash or to do pest control according to the product previously insert into the tank. The perfect model for sanitizing and pre-washing external surfaces and garden furnitures, for doing mosquito control and for garden applications such as spraying.*

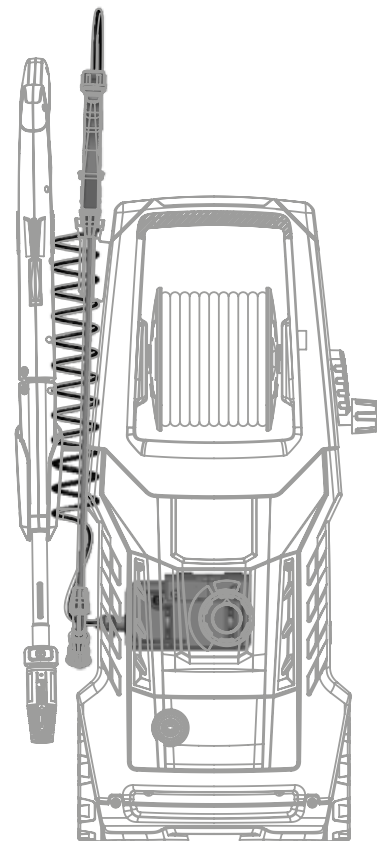

Attivando **II Washing Mode** si potrà utilizzare la lancia per lavare e risciacquare le superfici preventivamente trattate. Adatta per cancellate, muri e pavimentazioni nonché bici, moto ed automobili.

*Activate **II Washing Mode** to use the lance to wash, clean and rinse the previously treated surfaces. With its powerful motorpump it's suitable to remove dirt from fences, walls, bicycles, motorcycles and cars.*

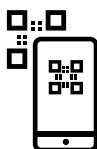
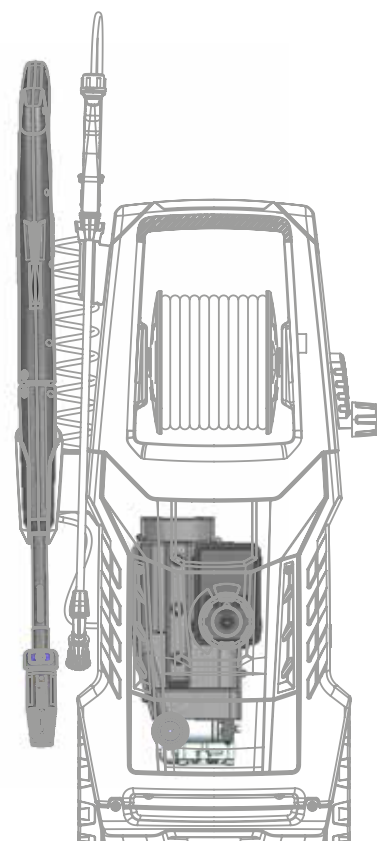

DHS Series 2KA

IDROPULTRICI ALTA PRESSIONE
high pressure washer



avvolgitubo statico con tubo
alta flessibilità 6 m
*static hose reel with super
flexible hose 6 m*



interruttore rotativo a 3 posizioni
off/spraying mode/washing mode
*3 positions rotative switch
off/spraying mode/washing mode*



tubo flessibile
per modalità spraying
*flexible hose
for spraying mode*



serbatoio integrato
built-in tank



battistrada in gomma
rubber wheels



dispositivo click -fast
*click-fast connection
drive*



Caratteristiche Generali

- Manico con avvolgitubo statico
- Lancia Washing
- Lancia Spraying
- Pompa a 3 pistoni assiali comandati dal piattello oscillante, testa in alluminio
- Pistoni in acciaio inox temperato
- Valvola di sicurezza automatica con azzeramento della pressione nella testa pompa
- Motore universale elettrico con protezione termica ed elettropompa a vibrazione monofase
- Ugello rotante
- Tubo alta flessibilità 6 m
- Funzione autoadescante

General Features

- Two-wheel trolley with handle and static hose reel
- Lancia Washing
- Lancia Spraying
- 3 Axial stainless steel pistons wobble-plate pumps
- Tempered stainless steel pistons
- Automatic by-pass valve with pump head pressure discharge
- Single-phase universal motor with thermal protector and electric single-phase vibrating pump.
- Rotary nozzle
- Super flexible hose (6 m)
- Self-priming function

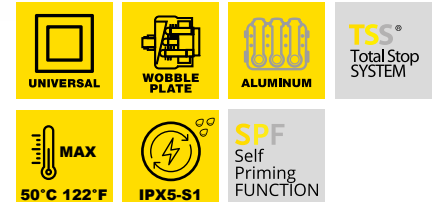

MOD	COD									
			bar	psi	l/h	gph	kW	Hz	V	kg
2KA	15149	SPRAYING MODE	4	58	0,3	0,08	0,035	50	220-240~	11,6
		WASHING MODE	160	2320	460	122	2,2	50	220-240~	

Accessori standard Standard accessories



4381485

4381495
(42 cm)

4821170
(6 m)



5340371



47022



5340380



4100800



4101500





2 DTS DUALTECH SYSTEM

Prestazioni migliori e risparmio di tempo.

*Improve performance.
Save time*

1 POWER UNIT → **ECO SOFT CLEANING**

Attiva "1 POWER UNIT" per un livello di lavaggio leggero particolarmente indicato per la pulizia di biciclette, moto e auto e adatto anche a staccionate, mobili da giardino e tende da sole.

Activate "1 POWER UNIT" when you need to remove light dirt from bicycles, motorcycles, cars or you want fences, outdoor furniture and sun shades to seem like new.

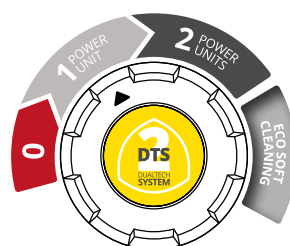

2 POWER UNITS → **FAST CLEANING**

Sfrutta la sinergia di "2 POWER UNITS" insieme quando devi eliminare macchie e sporco ostinato da pavimentazione di pietra o cemento, rivestimenti e muri di mattoni, attrezzature da costruzione.

Exploit the synergy of "2 POWER UNITS" together when you need to get rid of the toughest dirt and stains from stone and cement flooring, brick walls and sidings, roofs or construction applications.

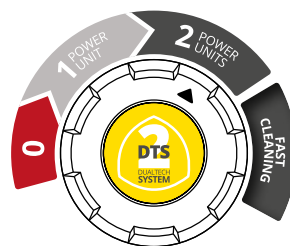

+50% WPP

Maggiore portata per una maggiore potenza prestazionale.

Stronger flow rate for a stronger washing power performance.

+70% FASTER **TWIN NOZZLE**

2X EFFECTIVE



Getto doppio, tempi dimezzati con l'esclusivo accessorio Twin Nozzle.

Twin Flow si presenta equipaggiata con l'imperdibile accessorio, incluso nella confezione, utile per incrementare la performance di pulizia di grandi superfici risparmiando tempo e fatica. È particolarmente indicato per il lavaggio di muri in cemento o mattoni, pavimentazioni e piscine.

Double water jet, halved cleaning time with Twin Nozzle.

Twin Flow features the ultimate must-have lance accessory, included inside the packaging, that will boost wide surfaces cleaning performance, saving your time and effort. It is perfect to wash concrete or brick walls, floorings, pools in a very efficient way.

4K TWIN FLOW

IDROPULITRICI ALTA PRESSIONE
high pressure washer

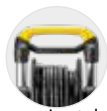

manico telescopico con avvolgitubo statico
telescopic handle with static hose reel



selettore rotativo a 3 posizioni off/Eco Soft Cleaning/Fast Cleaning
3 positions rotative switch off/Eco Soft Cleaning/Fast Cleaning



filtro ingresso acqua ispezionabile
inspectable water intake filter



avvolgitubo statico con tubo alta flessibilità 8 m
static hose reel with super flexible hose 8 m



schiumogeno alta pressione
high pressure foam lance



porta accessori integrato
built-in accessory holders

battistrada in gomma
rubber wheels



Caratteristiche Generali

- Manico telescopico con avvolgitubo in pressione
- 2 Pompe a 3 pistoni assiali comandati dal piattello oscillante, testa in alluminio
- Pistoni in acciaio inox temperato
- Valvola di sicurezza automatica con azzeramento della pressione nella testa pompa
- Doppio motore universale con protezione termica
- Sistema twin nozzle con doppio ugello rotante
- Tubo alta flessibilità (8 m)
- Funzione autoadescante

General Features

- Two-wheel trolley with handle and in-pressure hose reel
- Two 3 Axial stainless steel pistons wobble-plate pumps
- Tempered stainless steel pistons
- Automatic by-pass valve with pump head pressure discharge
- Twin single-phase universal motor with thermal protector
- Twin nozzle system with double rotary nozzle
- Super flexible hose (8 m)
- Self-priming function

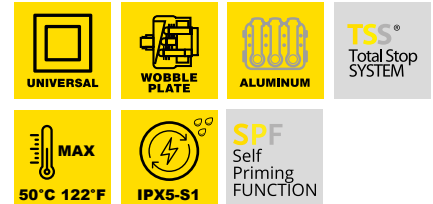

MOD	COD	MAX	MAX							KG NET
		bar	psi	l/h	gph	kW	rpm	Hz	V	kg
4K TWIN FLOW	14823	150	2200	810	214	2,5	3400	50-60	220-230~	14

Accessori standard Standard accessories



4381485

4381495

4581012



4581000

4581030 (8 m)

4580990 (x2)

4580982





5K TWIN FLOW

IDROPULTRICI ALTA PRESSIONE high pressure washer



Caratteristiche Generali

- Manico telescopico con avvolgitubo in pressione (tubo AP 8m)
- 2 Pompe a 3 pistoni assiali comandati dal piattello oscillante, testa in alluminio
- Pistoni in acciaio inox temperato
- Valvola di sicurezza automatica con azzeramento della pressione nella testa pompa
- Doppio motore universale con protezione termica
- Lunghezza cavo elettrico 5m
- Sistema twin nozzle con doppio ugello rotante
- Ugello multi funzione 5 in 1
- Tubo alta flessibilità (8 m)
- Funzione autoadescente

General Features

- Two-wheel trolley with handle and in-pressure hose reel (8m HP hose)
- Two 3 Axial stainless steel pistons wobble-plate pumps
- Tempered stainless steel pistons
- Automatic by-pass valve with pump head pressure discharge
- Twin single-phase universal motor with thermal protector
- Electric cable length 5m
- Twin nozzle system with double rotary nozzle
- Multifunction 5 in 1 nozzle
- Super flexible hose (8 m)
- Self-priming function

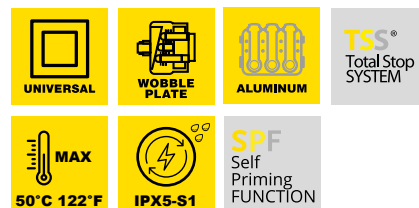

MOD	COD	MAX	MAX							KG NET
		bar	psi	l/h	gph	kW	rpm	Hz	V	kg
5K TWIN FLOW	14950	160	2300	850	225	2,7	3400	50-60	220-230~	14,6



Accessori standard Standard accessories





Caratteristiche Generali

- Carrello a 2 ruote completo di manico
- Pompa a 3 pistoni assiali comandati dal piattello oscillante, testa in alluminio
- Pistoni in acciaio inox temperato
- Valvola di sicurezza automatica con azzeramento della pressione nella testa pompa
- Sistema di arresto totale dell' idropulitrice a distanza
- Motore ad induzione con protezione
- Aspirazione detergente diretta con serbatoio incorporato
- Capacità del serbatoio detergente 1,4 l
- Tubo rinforzato con treccia in acciaio (8 m)
- Funzione autoadescante

General Features

- Two-wheel trolley with handle
- 3 Axial stainless steel pistons wobble-plate pump with aluminium head
- Tempered stainless steel pistons
- Automatic by-pass valve with pump head pressure discharge
- Remote control for total shut-down of high pressure washer
- Induction motor with thermal protection
- Built-in detergent tank for direct suction
- Detergent tank capacity 1.4 l
- Steel braided hose (8 m)
- Self-priming function

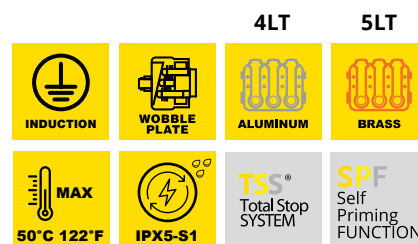

MOD	COD	MAX	MAX							KG NET
		bar	psi	l/h	gph	kW	rpm	Hz	V	kg
4LT	15549	150	2175	450	119	2,1	2800	50	220-240~	21,1
5LT	15550	160	2320	460	121	2,5	2800	50	220-240~	22,3



Accessori standard Standard accessories





CARATTERISTICHE GENERALI

Innovativo e pratico accessorio multifunzione per idropulitrici ad alta pressione che permette, grazie ad un semplice click, il passaggio dall'azione di lavaggio (**modalità CLEAN**) a quella di risciacquo e asportazione (**modalità SWEEP**). Grazie ai 3 ugelli, la **superficie pulente aumenta del 30%** consentendo un risparmio di tempo e di energia.

GENERAL FEATURES

*Innovative and practical multifunctional accessory for high pressure washers which allows, thanks to a simple click, the switch from the washing action (**CLEAN mode**) to the rinsing and sweeping action (**SWEEP mode**). Thanks to the 3 nozzles, **the cleaning surface increases by 30%**, saving time and energy.*



NEW



APPLICAZIONI - APPLICATIONS



pavimenti
flooring,
paving
stones



scale
stairs



casa
house



piscine
pools

CLEAN MODE

Nella modalità CLEAN l'azione meccanica combinata del getto ad alta pressione a tre ugelli e delle setole consente la rimozione e l'asportazione di ogni tipo di sporco dalla superficie trattata.

The CLEAN mode combines the mechanical action of three-nozzle high pressure jet with the bristles, allowing you to remove any type of dirt from treated surfaces

1



2 SWEEP MODE

Grazie alla sua posizione ergonomica la modalità SWEEP consente di allontanare lo sporco rimosso e i residui di detergente lasciando la superficie perfettamente pulita.

Thanks to its ergonomic position, the SWEEP mode allows you to remove the dirt previously detached and detergent residues, leaving the surface perfectly cleaned.

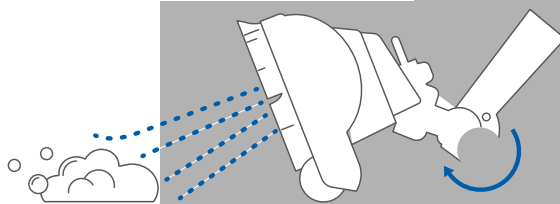

+30% di superficie pulita*
of cleaned area*

*rispetto ad un normale patio cleaner
*compared to a normal patio cleaner



		EASY	2LT	2K X-TRA	2KA DHS	4K	5K	4LT	5LT	
Pistola Trigger gun		3080060+ 3080070	S							
		4381485	S	S	S	S	S			
		4381913						S	S	
		5340371			S					
Estensione lancia Lance extension		47022		S						
		4381495	S	S	S	S	S			
Testina getto regolabile Adjustable jet nozzle		4101550		S	S					
		4381830	S							
		4581000			S	0				
Testina getto rotante Rotary jet nozzle		4100800	S	S	S					
		4580990			S	S				
Portatestina doppio Twin nozzles holder		4581012			S	S				
Testina cinque in uno Five in One nozzle		4102370			0	S				
		4102320			0	0				
Lancia getto regolabile Lance with adjustable spray nozzle		3080090	S							
		4821180					S			
		4382380						S		
Lancia getto rotante Rotary lance		3080080	S							
		4821190					S	S		
Tubo spiralato 6m Spiral hose 6m		5340380		S						
Tubo AP Hose HP		3500350 (5 m)	S							
		4821170 (6 m)	0	S	S	S				
		4581030 (8 m)					S			
		4581180 (8 m)						S		
Tubo armato AP Reinforced HP hose		43642 (8 m)						S	S	
Prolunga tubo 8m Extension hose 8m		46380	0	0	0	0	0	0	0	
Prolunga tubo armato 8m Reinforced extension hose 8m		43740						0	0	
Schiumogeno con serbatoio Foam lance bottle		3480200 (0,5 l)	S							
		4381500		S						
		4383500 (0,4 l)	0	0	S	0			0	
		4580981 (0,6 l)					S	S		
Kit schiumogeno alta pressione High pressure foam lance bottle		4581160 (0,6 l)							0	0
		43724	0	0	0	0	0	0	0	0
Kit aspirazione acqua Water suction kit		43724	0	0	0	0	0	0	0	

Legenda: "S" Accessorio di serie - "O" Accessorio opzionale / "S" On board accessory - "O" Optional accessory
* Accessorio fornito in cartone / Accessory supplied in carton box



			EASY	2LT	2KX-TRA	2KA-DHS	4K	5K	4LT	5LT
Lavapavimenti Ø 25cm <i>Patio cleaner Ø 25 cm</i>		43728	0	0	0	0				
Lavapavimenti con serbatoio detergente Ø30cm <i>Patio cleaner with detergent tank Ø30cm</i>		43729	0	0	0	0			0	
		43730								0
Aquasweeper		46702	0	0	0	0	0	0		
Spazzola lavante <i>Cleaning brush</i>		47004	0	0	0	0			0	0
		47005					0	0		
Spazzola Brush		Fissa / Fixed 2620730	0	0	0	0			0	0
		Fissa / Fixed 43731	0	0	0	0	0	0	0	0
Spazzola Brush		Rotante / Rotary 43732	0	0	0	0	0	0	0	0
		43733 (10 m)	0	0	0	0	0	0	0	0
Kit pulizia tubazioni <i>Pipe drain kit</i>		43734 (16 m)	0	0	0	0	0	0	0	0
		43735	0	0	0	0	0	0	0	0
Kit filtro acqua <i>Water filter kit</i>		43736	0	0	0	0	0	0	0	0
Filtro acqua ispezionabile <i>Inspectable water filter (pcs 3)</i>		43737	0	0	0	0	0	0	0	0
Kit attacco rapido <i>Click fast kit</i>		43737	0	0	0	0	0	0	0	0











			EASY	2LT	2KX-TRA	2KA-DHS	4K	5K	4LT	5LT
		43741	0	0	0	0				
		47107					0	0		
Kit lancia sabbiente <i>Sandblasting lance kit</i>		43742							0	
		43750								0
Sabbia calibrata e filtrata <i>Calibrated, filtered sand</i>		3207 (5 Kg)	0	0	0	0	0	0	0	0
		41770 (25 Kg)	0	0	0	0	0	0	0	0
Kit lancia sottoscocca DRS <i>Underbody lance kit DRS</i>		43743	0							
Kit adattatore lancia sottoscocca <i>Underbody lance adapter kit</i>		4300061	0	0	0	0	0	0		
Kit lancia sottoscocca PRO <i>Underbody lance kit PRO</i>		43744							0	0
Kit adattatori <i>Adapters kit</i>		43745	0	0	0	0	0	0	0	0
Kit adattatori accessori <i>Accessories adapters kit</i>		43746	0	0	0	0	0	0	0	0
Kit estensione lancia 1,6 m <i>Extension lance kit 1,6 m</i>		4102230	0	0	0	0	0	0	0	0



Legenda: "S" Accessorio di serie - "O" Accessorio opzionale / "S" On board accessory - "O" Optional accessory
* Accessorio fornito in cartone / Accessory supplied in carton box



DETERGENTS

ACCESSORI accessories

			EASY	2LT	2K X-TRA	2KA DHS	4K	5K	4LT	5LT
Detergenti <i>Detergents</i>	 1l	Universale / <i>Universal</i> (43725)	0	0	0	0	0	0	0	0
	 1l	Moto / <i>Bikes</i> (43726)	0	0	0	0	0	0	0	0
	 1l	Barche / <i>Boats</i> Auto / <i>Cars</i> (43727)	0	0	0	0	0	0	0	0
	 1l	Decking / <i>Wood surfaces</i> (43487)	0	0	0	0	0	0	0	0
	 1l	Tende da sole / <i>awnings</i> (43483)	0	0	0	0	0	0	0	0
	 1l	Vetri / glasses (43488)	0	0	0	0	0	0	0	0
	 1l	Pannelli solari / solar panels (43485)	0	0	0	0	0	0	0	0
Detergenti <i>Detergents</i>	 1l	Erba sintetica / synthetic grass (43484)	0	0	0	0	0	0	0	0
	 1l	Muri e pietre / wall&stones (43486)	0	0	0	0	0	0	0	0
	 5l	Universale / <i>Universal</i> (43491)	0	0	0	0	0	0	0	0

			EASY	2LT	2K X-TRA	2KA DHS	4K	5K	4LT	5LT
Detergenti HYG <i>Detergents HYG</i>	 1l	HYG 1l (46705)	0	0	0	0	0	0	0	0
	 5l	HYG 5l (46706)	0	0	0	0	0	0	0	0
	 12l	HYG 12l (46707)	0	0	0	0	0	0	0	0



2 POWER UNITS

FAST CLEANING

DTS
1/2hp

2

RESTORE

RESTORE

1.1hp

2hp

CLEANING DIVISION

LINEA PRO COLD

Pro Cold line

Annovi Reverberi ha realizzato una gamma di prodotti, ideale per gli artigiani più esigenti, che ben si coniuga alle loro esigenze professionali. Estremamente versatili i prodotti della linea PRO rispondono perfettamente alle necessità lavorative di artigiani idraulici, carrozzieri, muratori; un costante supporto a ciascuna professione che consente risparmio tempo ma soprattutto fatica. Utilizzo intuitivo, accessori professionali e manovrabilità estrema rendono i prodotti PRO COLD la miglior scelta per la categoria.

Annovi Reverberi has produced a range of products ideal for the most demanding craftsmen, carefully tailored to their professional requirements. Extremely versatile, the PRO line products are the perfect fit for the working needs of plumbers, car body repair workshops and builders; constant support for each trade, saving time and above all effort. User-friendliness, professional accessories and extremely easy handling make PRO COLD products the right choice for this category.

○ LIGHTPRO

Fascia di idropultrici progettate per utilizzatori esperti che hanno necessità di eseguire lavori di pulizia abbastanza frequenti e che richiedono una abbondante riserva di potenza.

High pressure washer category designed for skilled users tackling cleaning quite frequent jobs operations which need plenty of power in reserve.

● HEAVYPRO

Fascia di idropultrici progettate per professionisti che hanno necessità di eseguire lavori di pulizia molto frequenti che richiedono le massime prestazioni.

High pressure cleaner category designed for professionals, dealing with cleaning high frequent jobs that need the very highest-performing appliances.

PRO COLD APPLICATIONS



edilizia
construction



agricoltura
zootecnica
agriculture
zootechny



artigianato
crafts



car wash



automotive



Caratteristiche Generali

- Carrello a due ruote completo di manico ed avvolgitubo
- Pompa a 3 pistoni assiali comandati dal piattello oscillante
- Pistoni in acciaio inox temperato
- Valvola di sicurezza automatica con azzeramento della pressione nella testa pompa
- Manometro
- Motore elettrico monofase ad induzione con protezione termica
- Regolazione della pressione
- Ugello rotante
- Tubo rinforzato con treccia in acciaio (10 m)

General Features

- Two-wheel trolley with handle and hose reel
- 3 Axial stainless steel pistons wobble-plate pump
- Tempered stainless steel pistons
- Automatic by-pass valve with pump head pressure discharge
- Pressure gauge
- Single-phase induction motor with thermal protector
- Pressure adjustment
- Rotary nozzle
- Steel braided hose (10 m)

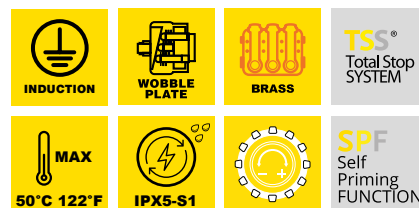

MOD	COD	MAX	MAX		NET					
		bar max	psi max	l/h max	gph max	kW	rpm	Hz	V	kg
5SP	15559	170	2500	500	132	2,5	2800	50	220-230~	24,4

Accessori standard Standard accessories



4383516

4821180

4821190

4581160

4581170



SPARK 70 - SPARK 72

IDROPULTRICI ALTA PRESSIONE
high pressure washer

OLIGHTPRO



Caratteristiche Generali

- Pompa a 3 pistoni in ceramica con sistema biella-manovella
- Valvola di sicurezza automatica con azzeramento della pressione nella testa pompa
- Motore elettrico monofase a induzione con protezione termica
- Regolazione della pressione
- Aspirazione detergente incorporata
- Tubo rinforzato con treccia in acciaio (8 m)
- Funzione autoadescente

General Features

- Triplex pump with ceramic pistons and connecting rod system
- Automatic by-pass valve with pump head pressure discharge
- Single-phase induction motor with thermal protection
- Pressure adjustment
- Built-in detergent suction
- Steel braided hose (8 m)
- Self-priming function

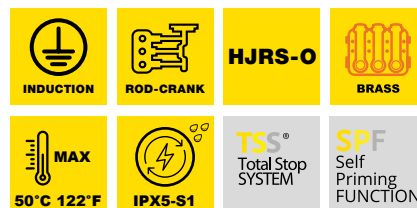

MOD	COD	MAX		MAX		kW	rpm	Hz	V	KG NET
		bar max	psi max	l/h max	gph max					
SPARK70	15344	160	2320	500	132	2,5	2800	50	230~	20
SPARK72	15054	150	2175	630	166	2,9	2800	50	230~	23,6

Accessori standard Standard accessories



47023



43954 (spark 70)
43956 (spark 72)



47024



OPTIONAL / OPZIONALE
Cod. 43972
Carrello con manico orientabile
Orientable holder
ø 25cm



OPTIONAL / OPZIONALE
Cod. 41738
Kit avvolgitubo per carrello
Hose reel kit trolley version



OPTIONAL / OPZIONALE
Cod. 47704
Unità di montaggio a muro
senza tubo
Wall mounted kit without hose



OLIGHTPRO



Caratteristiche Generali

- Pompa a 3 pistoni in ceramica con sistema biella-manovella
- Valvola di sicurezza automatica con azzeramento della pressione nella testa pompa
- Motore elettrico monofase a induzione con protezione termica
- Regolazione della pressione
- Manometro
- Aspirazione detergente incorporata
- Tubo rinforzato con treccia in acciaio (8 m)
- Funzione autoadescante

General Features

- *Triplex pump with ceramic pistons and connecting rod system*
- *Automatic by-pass valve with pump head*
- *pressure discharge*
- *Single-phase induction motor with thermal protection*
- *Pressure adjustment*
- *Pressure gauge*
- *Built-in detergent suction*
- *Steel braided hose (8 m)*
- *Self-priming function*



MOD	COD	MAX		MAX		MAX				KG NET
		bar max	psi max	l/h max	gph max	kW	rpm	Hz	V	kg
R.613	14305	150	2200	500	132	2,5	2800	50	220-240~	16,8
R.614	14307	160	2300	510	135	2,9	2800	50	220-240~	18,4

Accessori standard *Standard accessories*





VIP REVO KART

IDROPULTRICI ALTA PRESSIONE
high pressure washer

OLIGHTPRO



porta accessori
built-in accessories holder

filtro ingresso acqua
ispezionabile
inspectable water
intake filter

telaio in acciaio
verniciato
foldable painted steel
frame

pulsante di sgancio rapido
easy unlock button

battistrada in
gomma
rubber wheels





Caratteristiche Generali

- Carrello a 2 ruote completo di manico
- Pompa a 3 pistoni in ceramica con sistema biella-manovella
- Valvola di sicurezza automatica con azzeramento della pressione nella testa pompa
- Motore elettrico monofase a induzione con protezione termica
- Regolazione della pressione
- Manometro
- Aspirazione detergente incorporata
- Tubo rinforzato con treccia in acciaio (8 m)
- Funzione autoadescente

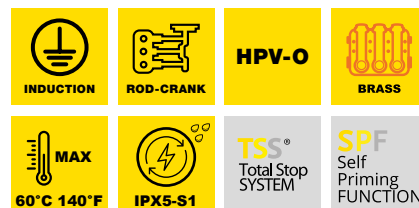
General Features

- Two-wheel trolley with handle
- Triplex pump with ceramic pistons and connecting rod system
- Automatic by-pass valve with pump head
- pressure discharge
- Single-phase induction motor with thermal protection
- Pressure adjustment
- Pressure gauge
- Built-in detergent suction
- Steel braided hose (8 m)
- Self-priming function



MOD	COD	 MAX	 MAX		 KG NET					
		bar max	psi max	l/h max	gph max	kW	rpm	Hz	V	kg
R.613K	14306	150	2200	500	132	2,5	2800	50	220-240~	29,4
R.614K	14308	160	2300	510	135	2,9	2800	50	220-240~	31

Accessori standard Standard accessories



47023



41269 (R.613)
41806 (R.614)



47025

OPTIONAL / OPZIONALE
Cod. 41738



Kit avvolgitubo senza tubo
Hose reel without hose

OPTIONAL / OPZIONALE
Cod. 41739



Unità di montaggio a muro
senza tubo
Wall mounted kit without hose

WALL MOUNTED & KART UNIT

- 1** UNITÀ DI MONTAGGIO A MURO
Wall mounted kit
- 2** KIT AVVOLGITUBO A MURO
Wall mounted hose reel
- 3** TUBO AD ALTA PRESSIONE DI 15M
HP 15mt hose.
- 4** PULSANTE DI SGANCIO RAPIDO
Easy unlock button
- 5** RUOTE AD ALTA STABILITÀ
High stability wheels
- 6** KIT CARRELLO CON TELAIO
PIEGHEVOLE IN ACCIAIO VERNICIATO
Trolley kit with foldable painted steel frame
- 7** PORTA ACCESSORI INTEGRATO
Built-in accessory holder



UNITÀ DI MONTAGGIO A MURO

AR COD. 41880
EAN COD. 8016287418805

Kit avvolgitubo a muro con tubo ad alta pressione di 15 m.

WALL MOUNTED UNIT
*Wall mounted hose reel with
HP hose 15m hose.*

KIT CARRELLO

AR COD. 41869
EAN COD. 8016287418690

Telaio pieghevole in acciaio verniciato con grandi ruote durature di ø250 mm per un migliore bilanciamento.

TROLLEY KIT
Foldable painted steel frame with durable rubber wheels ø250 mm for perfect balancing.



NEW BLITZ 1510

DUAL PRO APPLIANCE SYSTEM



DPA è l'innovativo sistema tecnologico che permette di selezionare la modalità di funzionamento dell'idropulitrice agendo sul selettore di accensione a tre posizioni: **OFF / I / B**.

*DPA is the innovative technological system that allows to select the operating mode of the high pressure washer by acting on the three position switch: **OFF / I / B**.*



THE POWER OF CLEANING

Il nuovo modello BLITZ 1510, equipaggiato con l'innovativo sistema tecnologico DPA, appartiene alla gamma di macchine professionali. Pensata per l'utilizzatore privato esigente o per il professionista che intende svolgere lavori di rimozione di sporco pesante, è ideale per lavare l'auto, le varie zone ed oggetti dell'esterno casa e adatta per la manutenzione di camion e macchine agricole.

THE POWER OF CLEANING

The new model AR BLITZ 1510, equipped with the technological DPA system, belongs to the range of professional machines. Created for the demanding of private user or for the professional who wants to carry out heavy dirt removal work, it is ideal for washing cars, the various areas and objects outside of the house and suitable for the maintenance of trucks and agricultural machinery.



La nuova idropulitrice BLITZ 1510 è dotata di un selettore a tre posizioni: OFF / TSS / BY-PASS.

The new BLITZ 1510 high pressure washer is equipped with a three-position switch: OFF / TSS / BY-PASS.

I-TOTAL STOP SYSTEM

Particolarmente indicato durante il normale utilizzo dell'idropulitrice permette l'arresto immediato della stessa quando viene rilasciata la pistola. Questo sistema garantisce minori consumi energetici e diminuisce l'usura di pompa e motore.

Particularly suitable during the normal use of the pressure washer and allows the immediate stop of the same when the gun is released. This system guarantees lower energy consumption and reduces the wear of the pump and motor.

B- BY-PASS SYSTEM

Il sistema by-pass è indicato per condizioni di uso intensivo in cui l'idropulitrice è soggetta a frequenti arresti e ripartenze o se viene utilizzata in condizioni ambientali gravose (es. alte temperature, alta umidità ambientale, ambiente con bassa circolazione di aria).

The by-pass system is suitable for intensive use conditions in which the pressure washer is subject to frequent stops and restarts or if it is used in harsh environmental conditions (e.g. high temperatures, high ambient humidity, environment with low air circulation).



BLITZ 1510

IDROPULITRICI ALTA PRESSIONE
high pressure washer



HEAVYPRO



Caratteristiche Generali

- Pompa a 3 pistoni in ceramica con sistema biella-manovella
- Valvola di sicurezza automatica con azzeramento della pressione nella testa pompa
- Motore elettrico monofase a induzione con protezione termica
- Regolazione della pressione
- Manometro
- Kit aspirazione detergente
- Opzione by-pass
- Pistola con swivel
- Funzione autoadescente
- Tubo rinforzato con treccia in acciaio (10 m)

General Features

- Triplex pump with ceramic pistons and connecting rod system
- Automatic by-pass valve with pump head pressure discharge
- Single-phase induction motor with thermal protection
- Pressure adjustment
- Pressure gauge
- Detergent suction kit
- By-pass option
- Gun with swivel
- Self-priming function
- Steel braided hose (10 m)

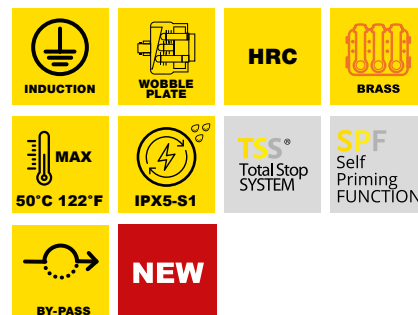

MOD	COD	MAX				MAX								KG NET
		bar max	bar work	psi max	psi work	l/h work	gph work	hp	kW	kW work	rpm	Hz	V	kg
BLITZ 1510	15588	150	120	2175	1740	600	159	2,7	2,0	2,6	1450	50	220-240~	27

Accessori standard Standard accessories



WALL MOUNTED FOR ALL 6 SERIES MODELS

- 1** UNITÀ DI MONTAGGIO A MURO
Wall mounted kit
- 2** KIT AVVOLGITUBO A MURO
Wall mounted hose reel
- 3** TUBO AD ALTA PRESSIONE DI 15M
HP 15mt hose.
- 4** PULSANTE DI SGANCIO RAPIDO
Easy unlock button

UNITÀ DI MONTAGGIO A MURO

AR COD. 47705

EAN COD. 8016287477055



- 5** RUOTE AD ALTA STABILITÀ
High stability wheels
- 6** KIT CARRELLO CON TELAIO PIEGHEVOLE IN ACCIAIO VERNICIATO
Trolley kit with foldable painted steel frame
- 7** PORTA ACCESSORI INTEGRATO
Built-in accessory holder

KIT CARRELLO

AR COD. 43972

EAN COD. 8016287439725



PROLINER RS 1510

IDROPULTRICI ALTA PRESSIONE
high pressure washer

HEAVYPRO



Caratteristiche Generali

- Carrello a due ruote completo di manico
- Pompa a 3 pistoni in ceramica, con sistema biella-manovella
- Valvola di sicurezza automatica con azzeramento della pressione nella testa pompa
- Motore elettrico trifase con protezione termica
- Regolazione della pressione
- Manometro
- Aspirazione detergente incorporata
- Aspirazione detergente regolabile
- Capacità del serbatoio detergente 2l
- Funzione autoadescante
- Tubo rinforzato con treccia in acciaio (10 m)

General Features

- Two-wheel trolley with handle
- Triplex pump with ceramic pistons and connecting rod system
- Automatic safety valve with pressure shut-off at pump head
- Three-phase heavy duty motor with thermal protector
- Pressure adjustment
- Pressure gauge
- Built-in detergent suction
- Adjustable detergent injector
- Detergent tank capacity 2l
- Self-priming function
- Steel braided hose (10 m)

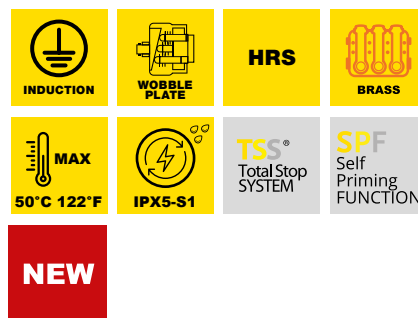

MOD	COD	MAX		MAX								KG NET		
		bar max	bar work	psi max	psi work	l/h work	gph work	hp	kW	kW work	rpm	Hz	V	kg
RS1510 TSS [®]	22670-V	150	120	2175	1740	630	166	3	2,2	3	1450	50	230~	41,5

Accessori standard Standard accessories



46880



41747



3961050 (10 m)





HEAVYPRO



manometro
pressure gauge



manico ergonomico
ergonomic handle

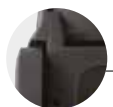

porta accessori
built-in accessories holder



serbatoio detergente integrato
built-in detergent tank



battistrada in gomma
rubber wheels



filtro ingresso acqua ispezionabile
inspectable water intake filter

Caratteristiche Generali

- Carrello a due ruote completo di manico
- Pompa a 3 pistoni in ceramica, con sistema biella-manovella
- Valvola di sicurezza automatica con azzeramento della pressione nella testa pompa
- Motore elettrico trifase con protezione termica
- Regolazione della pressione
- Manometro
- Aspirazione detergente incorporata
- Aspirazione detergente regolabile
- Capacità del serbatoio detergente 2l
- Funzione autoadescante
- Tubo rinforzato con treccia in acciaio (10 m)

General Features

- Two-wheel trolley with handle
- Triplex pump with ceramic pistons and connecting rod system
- Automatic safety valve with pressure shut-off at pump head
- Three-phase heavy duty motor with thermal protector
- Pressure adjustment
- Pressure gauge
- Built-in detergent suction
- Adjustable detergent injector
- Detergent tank capacity 2l
- Self-priming function
- Steel braided hose (10 m)

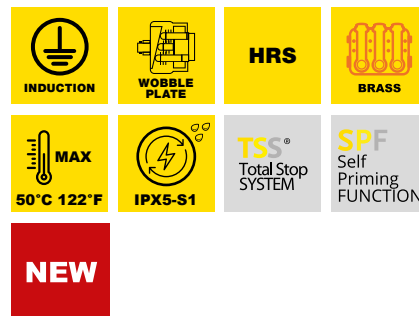

MOD	COD	MAX		MAX		MAX		MAX		MAX		MAX		KG NET
		bar max	bar work	psi max	psi work	l/h work	gph work	hp	kW	kW work	rpm	Hz	V	kg
RS1815TSS [®]	22671-V	180	150	2610	2175	900	238	5,5	4	5	1450	50	400 3~	43

Accessori standard Standard accessories



46880



41271



3961050 (10 m)



OPTIONAL / OPZIONALE
Cod. 40645

Kit avvolgitubo per carrello
Hose reel kit trolley version



MODENA

IDROPULTRICI ALTA PRESSIONE high pressure washer

UNIQUE DETAILS

- 1 MANUBRIO ERGONOMICO**
Ergonomic handle
- 2 PORTA ACCESSORI INTEGRATI**
Built-in accessories holders
- 3 RUOTE AD ALTA STABILITÀ**
High stability wheels ø 35 cm
- 4 PRESSIONE REGOLABILE**
Pressure adjustment
- 5 MANOMETRO**
Pressure gauge
- 6 FILTRO ACQUA ISPEZIONALE**
Inspectable water filter

Nata a Modena

Born in Modena

MODENA SERIES

La nuova Serie MODENA è il match perfetto tra design e prestazioni professionali. Nata a Modena, negli stabilimenti dedicati al cleaning, quest'idropulitrice ad acqua fredda ha delle dimensioni compatte e vanta un'estrema manovrabilità, che la rendono al tempo stesso robusta e maneggevole. L'impugnatura del manico è stata progettata per facilitarne l'utilizzo, come anche i diversi punti di rimessaggio accessori sulla macchina. Il pratico porta lancia, sul fianco della macchina ed il gancio per il tubo alta pressione nella parte posteriore. Si tratta di una gamma di idropultrici con dotazione completa e professionale, equipaggiate con accessori ideali per utilizzi continuativi e complessi.

MODENA SERIES

The new MODENA Series is the perfect match of design and professional performance. Created in Modena, in the plants that specialise in cleaning equipment, this cold water high pressure washer is compact in size and very manoeuvrable, making it both sturdy and agile. The handle grip is styled for user-friendliness, as are the various accessory stowing points on the appliance. These include the handy lance holder on the side of the appliance and the high pressure hose hook at the rear. It is a high pressure washer range with a full, professional outfit, equipped with the ideal accessories for continuous use on complex jobs.

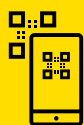



HEAVYPRO



Caratteristiche Generali

- Carrello a due ruote completo di manico
- Pompa a 3 pistoni in ceramica, con sistema biella-manovella
- Valvola di sicurezza automatica con azzeramento della pressione nella testa pompa
- Motore elettrico monofase a induzione con protezione termica
- Regolazione della pressione
- Manometro
- Aspirazione detergente incorporata
- Aspirazione detergente regolabile
- Funzione autoadescente
- Tubo rinforzato con treccia in acciaio (10 m)

General Features

- Two-wheel trolley unit with handle
- Triplex pump with ceramic pistons and connecting rod system
- Automatic safety valve with pressure shut-off at pump head
- Single-phase induction motor with thermal protection
- Pressure adjustment
- Pressure gauge
- Built-in detergent suction
- Adjustable detergent injector
- Self-priming function
- Steel braided hose (10 m)

930.960 980

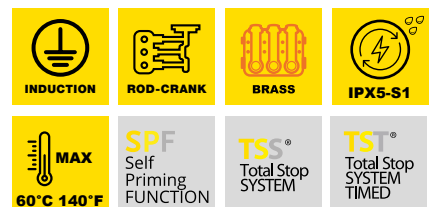

930.960 980

MOD	COD	MAX		MAX		MAX		MAX		MAX		MAX		kg NET
		bar max	bar work	psi max	psi work	l/h work	gph work	hp	kW	kW work	rpm	Hz	V	
MODENA 930	14736	150	120	2175	1740	630	166	3	2,2	3	1450	50	230~	43,6
MODENA 960	15547	200	180	2900	2610	840	221	6,1	4,5	5	1450	50	400 3~	45,5
MODENA 980	15546	230	200	3335	2900	900	238	7,5	5,5	7,4	1450	50	400 3~	52,2

Accessori standard Standard accessories

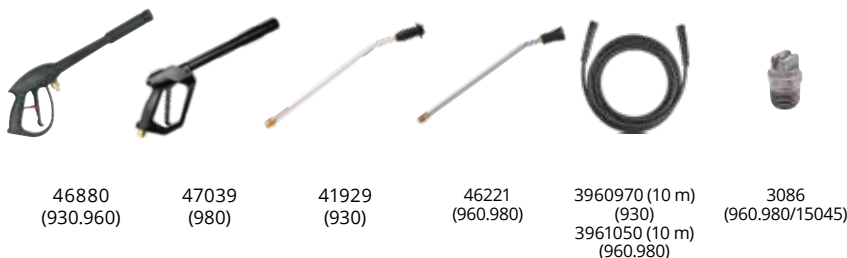



10 Series 1003 - 1003RLW

IDROPULITRICI ALTA PRESSIONE high pressure washer

HEAVYPRO



telaio in acciaio verniciato
painted steel frame



Regolazione della pressione
Pressure adjustment holder



porta accessori
built-in accessories holder



serbatoio detergente integrato
built-in detergent tank



battistrada in gomma
rubber wheels



Caratteristiche Generali

- Carrello robusto in metallo a due ruote completo di manico
- Pompa a 3 pistoni in ceramica, con sistema biella-manovella
- Valvola di by-pass automatica con azzeramento della pressione nella testa della pompa
- Motore elettrico a induzione monofase con protezione termica
- Regolazione della pressione
- Manometro
- Serbatoio detergente integrato (3 l) con aspirazione regolabile
- Tubo rinforzato con treccia in acciaio (10 m)
- Funzione autoadescante
- Pistola con swivel

General Features

- Heavy-duty two wheeled trolley with handle
- Triplex pump with ceramic pistons and connecting rod system
- Automatic by-pass valve with pressure with pump head pressure discharge
- Single-phase induction motor with thermal protector
- Pressure adjustment
- Pressure gauge
- Built-in detergent tank (3 l) with adjustable detergent injector
- Steel braided hose (10 m)
- Self-priming function
- Gun with swivel

 INDUCTION	 ROD-CRANK	 HRC	 BRASS
 MAX 60°C 140°F	 IPX5-S1	 TSS® Total Stop SYSTEM	 SPF Self Priming FUNCTION
NEW			

MOD	COD	MAX		MAX		MAX		MAX		MAX		MAX		KG NET
		bar max	bar work	psi max	psi work	l/h work	gph work	hp	kW	kW work	rpm	Hz	V	kg
1003	24385-V	150	120	2175	1740	630	166	3	2,2	3	1450	50	230~	40,6
1003RLW	24389-V*	150	120	2175	1740	630	166	3	2,2	3	1450	50	230~	53

* a richiesta / on request

Accessori standard Standard accessories



47039



3600650



3961050 (10 m) 1003
3600970 (15m) RLW



3600400 (low p.) Nero/Black
3600350 (0004) Rosso/Red
3600360 (1504) Giallo/Yellow
3600370 (2504) Verde/Green
3600380 (4004) Bianco/White



OPTIONAL / OPZIONALE
Cod. 42509

Kit avvolgitubo con tubo AP
Hose reel kit with AP hose



HEAVYPRO



telaio in acciaio verniciato
painted steel frame



Regolatore della pressione
Pressure adjustment



porta accessori
built-in accessories holder



serbatoio detergente integrato
built-in detergent tank



battistrada in gomma
rubber wheels

Caratteristiche Generali

- Carrello robusto in metallo a due ruote completo di manico
- Pompa a 3 pistoni in ceramica, con sistema biella-manovella
- Valvola di by-pass automatica con azzeramento della pressione nella testa della pompa
- Motore elettrico a induzione monofase con protezione termica
- Regolazione della pressione
- Manometro
- Serbatoio detergente integrato (3 l) con aspirazione regolabile
- Tubo rinforzato con treccia in acciaio (10 m)
- Funzione autoadescante
- Pistola con swivel

General Features

- Heavy-duty two wheeled trolley with handle
- Triplex pump with ceramic pistons and connecting rod system
- Automatic by-pass valve with pressure with pump head pressure discharge
- Single-phase induction motor with thermal protector
- Pressure adjustment
- Pressure gauge
- Built-in detergent tank (3 l) with adjustable detergent injector
- Steel braided hose (10 m)
- Self-priming function
- Gun with swivel

INDUCTION

ROD-CRANK

HRR

BRASS

MAX
60°C 140°F

IPX5-S1

TSS
Total Stop SYSTEM

SPF
Self Priming FUNCTION

NEW

MOD	COD	MAX				MAX		MAX			MAX			KG NET
		bar max	bar work	psi max	psi work	l/h work	gph work	hp	kW	kW work	rpm	Hz	V	
1005	15602	180	150	2610	2175	900	238	6,1	4,5	5	1450	50	400 3~	43

Accessori standard Standard accessories

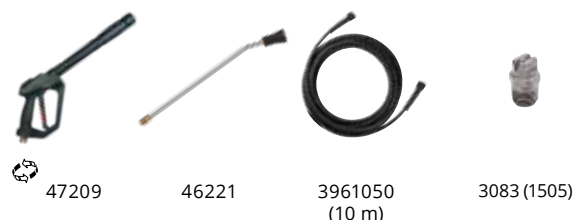



10 Series 1007.1007 RLW

IDROPULITRICI ALTA PRESSIONE high pressure washer

HEAVYPRO



telaio in acciaio verniciato
painted steel frame



Regolatore della pressione
Pressure adjustment



porta accessori
built-in accessories holder



serbatoio detergente integrato
built-in detergent tank



battistrada in gomma
rubber wheels

RLW



Caratteristiche Generali

- Carrello robusto in metallo a due ruote completo di manico
- Pompa a 3 pistoni in ceramica, con sistema biella-manovella
- Valvola di by-pass automatica con azzeramento della pressione nella testa della pompa
- Motore elettrico a induzione trifase con protezione termica
- Regolazione della pressione
- Manometro
- Pistola con SWIVEL
- Valvola di regolazione flangiata (VRZ)
- Serbatoio detergente integrato (3 l) con aspirazione regolabile
- Tubo rinforzato con treccia in acciaio (10 m)
- Funzione autoadescente
- Pistola con swivel

General Features

- Heavy-duty two wheeled trolley with handle
- Triplex pump with ceramic pistons and connecting rod system
- Automatic by-pass valve with pressure with pump head pressure discharge
- Three-phase induction motor with thermal protector
- Pressure adjustment
- Pressure gauge
- Gun with SWIVEL
- Flanged pressure unloader (VRZ)
- Built-in detergent tank (3 l) with adjustable detergent injector
- Steel braided hose (10 m)
- Self-priming function
- Gun with swivel

INDUCTION

ROD-CRANK

HRR

BRASS

60°C 140°F

IPX5-S1

TST
Total Stop SYSTEM
TIMED

SPF
Self Priming
FUNCTION

NEW

MOD	COD	MAX				MAX				MAX				kg NET
		bar max	bar work	psi max	psi work	l/h work	gph work	hp	kW	kW work	rpm	Hz	V	
1007	15477-V	230	200	3335	2900	900	238	7,5	5,5	7,4	1450	50	400 3~	54,8
1007RLW	15478-V*	230	200	3335	2900	900	238	7,5	5,5	7,4	1450	50	400 3~	61,6

* a richiesta / on request

Accessori standard Standard accessories



47209



46221



3961050 (10 m) 1007
3600970 (15 m) RLW



3086 (15045)

OPTIONAL / OPZIONALE
Cod. 42509



Kit avvolgitubo con tubo AP
Hose reel kit with AP hose



HEAVYPRO



telaio in acciaio verniciato
painted steel frame



Regolatore della pressione
Pressure adjustment



porta accessori
built-in accessories holder



serbatoio detergente integrato
built-in detergent tank



battistrada in gomma
rubber wheels

RLW



Caratteristiche Generali

- Carrello robusto in metallo a due ruote completo di manico ed avvolgitubo in pressione
- Pompa a 3 pistoni in ceramica, con sistema biella-manovella
- Valvola di by-pass automatica con azzeramento della pressione nella testa della pompa
- Motore elettrico a induzione trifase con protezione termica
- Regolazione della pressione
- Manometro
- Serbatoio detergente integrato (3 l) con aspirazione regolabile
- Tubo rinforzato con treccia in acciaio (10 m)
- Funzione autoadescante
- Pistola con swivel

General Features

- Heavy-duty two wheeled trolley with handle and in-pressure hose reel
- Triplex pump with ceramic pistons and connecting rod system
- Automatic by-pass valve with pressure with pump head pressure discharge
- Three-phase induction motor with thermal protector
- Pressure adjustment
- Pressure gauge
- Built-in detergent tank (3 l) with adjustable detergent injector
- Steel braided hose (10 m)
- Self-priming function
- Gun with swivel

INDUCTION	ROD-CRANK	HRK	BRASS
MAX 60°C 140°F	IPX5-S1	TST® Total Stop SYSTEM TIMED	SPF Self Priming FUNCTION
NEW			

MOD	COD	MAX		MAX		MAX		MAX		MAX		MAX		KG NET
		bar max	bar work	psi max	psi work	l/h work	gph work	hp	kW	kW work	rpm	Hz	V	
1009	15590	230	200	3335	2900	1260	333	9,6	7	9,3	1450	50	400 3~	57
1009RLW	15354-V*	230	200	3335	2900	1260	333	9,6	7	9,3	1450	50	400 3~	60,7

Accessori standard Standard accessories



47029



46221



3961050 (10 m) 1009
3600970 (15 m) RLW



3090
(2507)

OPTIONAL / OPZIONALE
Cod. 42659



Kit avvolgitubo con tubo AP
Hose reel kit with AP hose



10 Series 1015

IDROPULTRICI ALTA PRESSIONE high pressure washer

HEAVYPRO



Caratteristiche Generali

- Struttura robusta con cofano in acciaio inox
- Pompa a 3 pistoni in ceramica con sistema biella- manovella
- Valvola di by-pass automatica con azzeramento della pressione nella testa della pompa
- Motore elettrico trifase
- Valvola di regolazione flangiata (Gymatic 3/B - ID)
- Regolazione pressione
- Aspirazione detergente incorporata
- Tubo rinforzato con treccia in acciaio (10 m)
- Funzione autoadescante
- Pistola con swivel

General Features

- Heavy-duty frame with stainless steel cover
- Triplex pump with ceramic pistons and connecting rod system
- Automatic by-pass valve with pump head pressure discharge
- Heavy-duty three-phase motor
- Flanged unloader valve (Gymatic 3/B - ID)
- Pressure adjustment
- Built-in detergent suction
- Steel braided hose (10 m)
- Self-priming function
- Gun with swivel

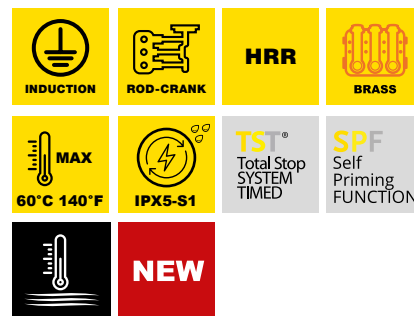

MOD	COD	MAX		MAX		MAX		MAX		MAX		MAX		kg NET
		bar max	bar work	psi max	psi work	l/h work	gph work	hp	kW	kW work	rpm	Hz	V	
1015	25283 -V	230	200	3335	2900	900	238	7,5	5,5	7,4	1450	50	400 3~	60

Accessori standard Standard accessories





HEAVYPRO



Caratteristiche Generali

- Struttura robusta con cofano in acciaio inox
- Pompa a 3 pistoni in ceramica con sistema biella- manovella
- Valvola di by-pass automatica con azzeramento della pressione nella testa della pompa
- Motore elettrico trifase
- Flangia con giunto elastico per accoppiamento pompa-motore
- Valvola di regolazione flangiata
- Regolazione pressione
- Aspirazione detergente incorporata
- Tubo rinforzato con treccia in acciaio (10 m)
- Funzione autoadescante
- Pistola con swivel

General Features

- Heavy-duty frame with stainless steel cover
- Triplex pump with ceramic pistons and connecting rod system
- Automatic by-pass valve with pump head pressure discharge
- Heavy-duty three-phase motor
- Flange with elastic joint for pump-motor coupling
- Flanged unloader valve
- Pressure adjustment
- Built-in detergent suction
- Steel braided hose (10 m)
- Self-priming function
- Gun with swivel

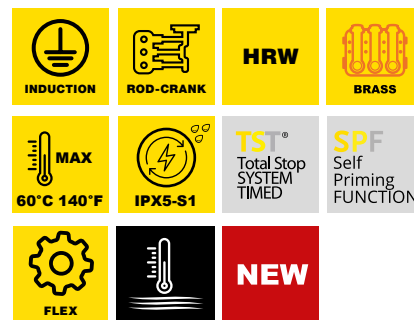

MOD	COD	MAX		MAX										KG NET
		bar max	bar work	psi max	psi work	l/h work	gph work	hp	kW	kW work	rpm	Hz	V	kg
1018	24491-V	230	200	3335	2900	900	238	7,5	5,5	7,4	1450	50	400 3~	80

Accessori standard Standard accessories





10 Series 1018H

IDROPULTRICI ALTA PRESSIONE high pressure washer

HEAVYPRO



Caratteristiche Generali

- Struttura robusta con cofano in acciaio inox
- Pompa a 3 pistoni in ceramica con sistema biella- manovella
- Guarnizioni in teflon che permettono di utilizzare acqua ad una temperatura massima in ingresso di 85°
- Valvola di by-pass automatica con azzeramento della pressione nella testa della pompa
- Motore elettrico trifase
- Flangia con giunto elastico per accoppiamento pompa-motore
- Valvola di regolazione flangiata
- Tubo rinforzato antitraccia (10 m)
- Battistrada antitraccia

General Features

- Heavy-duty frame with stainless steel cover
- Triplex pump with ceramic pistons and connecting rod system
- Teflon gasket to allow cleaning at high temperature. Max inlet water temperature 85°
- Automatic by-pass valve with pump head pressure discharge
- Heavy-duty three-phase motor
- Flange with elastic joint for pump-motor coupling
- Flanged unloader valve
- Non-marking reinforced hose (10 m)
- Non-marking wheels

INDUCTION	ROD-CRANK	WHW	NICKEL PLATED
MAX 85°C 185°F	IPX5-S1	FLEX	TST® Total Stop SYSTEM TIMED
NEW			

MOD	COD	MAX		MAX										KG NET
		bar max	bar work	psi max	psi work	l/h work	gph work	hp	kW	kW work	rpm	Hz	V	kg
1018H	25272 -V	230	200	3335	2900	900	237	7,5	5,5	7,4	1450	50	400 3~	80

Accessori standard Standard accessories





HEAVYPRO



Caratteristiche Generali

- Struttura robusta con cofano in acciaio inox
- Pompa a 3 pistoni in ceramica con sistema biella- manovella
- Testa pompa in ottone
- Valvola di by-pass automatica con azzeramento della pressione nella testa della pompa
- Arresto per microperdite
- Arresto dopo 1 ora di Total Stop
- Arresto per mancanza d'acqua
- Arresto per surriscaldamento motore
- Segnalazione d'errore tramite spia intermittente
- Motore elettrico trifase
- Regolazione pressione
- Aspirazione detergente incorporata
- Tubo rinforzato con treccia in acciaio (10 m)
- Funzione autoadescante
- Pistola con swivel

General Features

- Heavy-duty frame with stainless steel cover
- Triplex pump with ceramic pistons and connecting rod system
- Brass pump head
- Automatic by-pass valve with pump head pressure discharge
- Stop for leak detention
- Stop after 1 hour of total stop
- Stop for lack of water
- Stop for motor overloading
- System error warning light
- Heavy-duty three-phase motor
- Pressure adjustment
- Built-in detergent suction
- Steel braided hose (10 m)
- Self-priming function
- Gun with swivel

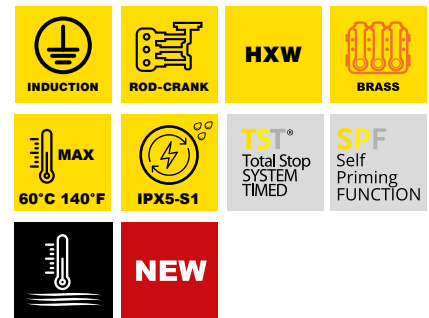

MOD	COD	MAX		MAX										KG NET
		bar max	bar work	psi max	psi work	l/h work	gph work	hp	kW	kW work	rpm	Hz	V	kg
1120	22374-V	230	200	3335	2900	1260	333	10	7,5	9,3	1450	50	400 3~	110

Accessori standard Standard accessories





SUPREME Series

THE POWER OF CLEANING

Idropultrici extra-flessibili - indipendenti dall'alimentazione elettrica. Alimentate a benzina o diesel, sono la soluzione ideale per la pulizia nel settore agricolo ed edile dove sono richieste prestazioni elevate ed un'estrema manovrabilità. Robuste e prestanti sono la risposta migliore per questo tipo di utilizzi gravosi e continuati. Le pompe montate su queste idropultrici sono costruite utilizzando esclusivamente materiali di qualità e anti-corrosione, quali l'ottone. Offrono quindi una lunga durata ed un'estrema facilità di manutenzione.

THE POWER OF CLEANING

Highly versatile high pressure washers - with no electricity supply needed. Operating on petrol or diesel, they are the ideal solution for cleaning in the farming and construction sectors, where high performance and extreme manoeuvrability are required. Tough and high-performing, they are the best solution for this type of heavy-duty, continuous use. The pumps installed on these high pressure washers are built only from top quality, corrosion-resistant materials, such as brass. This ensures a long working lifetime and exceptionally easy maintenance.



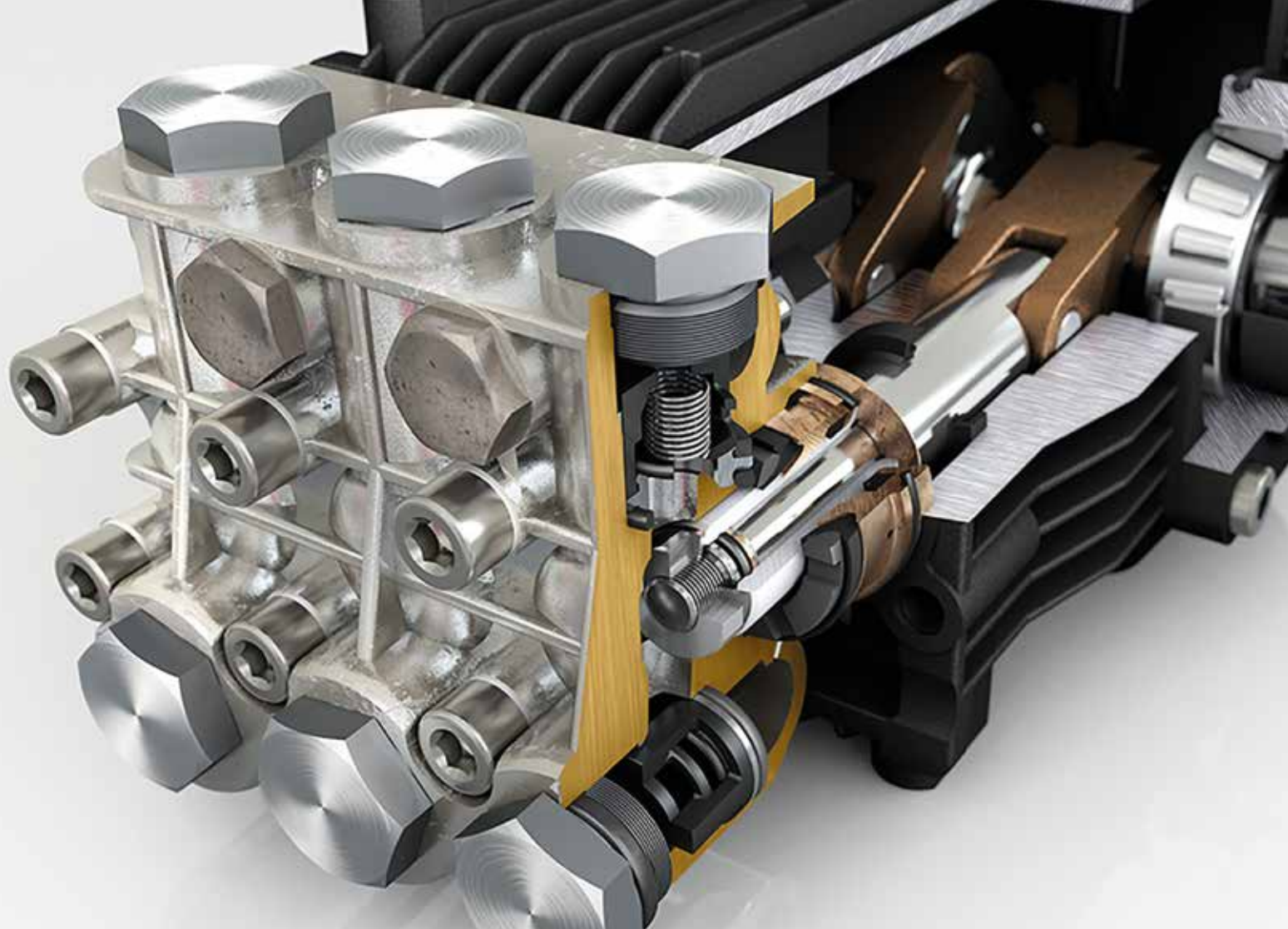

POMPA

modello RK

PUMP MODEL RK

POMPA AR AD ALTE PRESTAZIONI

Long-lasting AR pump

TESTA POMPA IN OTTONE FORGIATO

Forged brass pump head

SISTEMA BIELLA-MANOVELLA

Connecting rod-system

CONTROLLO QUALITÀ AR GARANTITA AL 100%

100% AR quality control system





SUPREME 40

ACCESSORI accessories

OLIGHTPRO



porta accessori
built-in accessories holder

filtro ingresso
acqua ispezionabile
inspectable water
intake filter

valvola termica
thermal valve

manico ergonomico
ergonomic handle

telaio in acciaio
verniciato
foldable painted steel
frame

battistrada in gomma
rubber wheels

Caratteristiche Generali

- Carrello completo di manico con due ruote e piedini antivibranti
- Pompa a 3 pistoni assiali comandati dal piattello oscillante
- Valvola di by-pass automatica
- Regolazione della pressione
- Valvola termica
- Aspirazione detergente incorporata
- Motorizzato HONDA (benzina), con sensore mancanza olio
- Livelli olio ispezionabili
- Tappi ed asole di scarico per agevolare la manutenzione ed il cambio olio
- Filtro acqua ispezionabile
- Soluzioni studiate per ottimizzare gli ingombri
- Tubo rinforzato con treccia in acciaio (8 m)

General Features

- Two-wheel trolley with tyres, handle and anti-vibrating feet
- 3 Axial stainless steel pistons wobble-plate pump
- Automatic by-pass valve
- Pressure adjustment
- Thermal valve
- Built-in detergent suction
- Powered by HONDA petrol engine with low oil level sensor
- Inspectable oil levels
- Discharge plugs and discharge slots to make easy the maintenance and the oil change
- Inspectable water filter
- Space-saving solutions
- Steel braided hose (8 m)

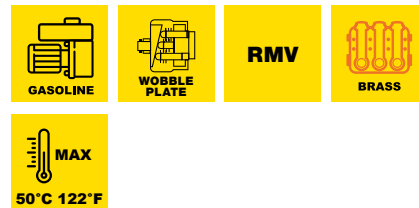

MOD	COD								
		bar max	psi max	l/h max	gph max	rpm	Engine	kW	kg
SUPREME 40	27750	200	2900	660	174	3400	HONDA GP160- 4,8	3,6	31,4

Accessori standard Standard accessories



47023



3600650



47024 (8 m)



3600400 (low pressure) Nero/Black
 3600930 (00035) Rosso/Red
 3600940 (15035) Giallo/Yellow
 3600960 (40035) Bianco/White



HEAVYPRO



Caratteristiche Generali

- Carrello completo di manico con due ruote e piedini antivibranti
- Pompa a 3 pistoni assiali comandati dal piattello oscillante
- Valvola di by-pass automatica
- Regolazione della pressione
- Valvola termica
- Aspirazione detergente incorporata
- Motorizzato RATO (benzina), con sensore mancanza olio
- Livelli olio ispezionabili
- Tappi ed asole di scarico per agevolare la manutenzione ed il cambio olio
- Filtro acqua ispezionabile
- Soluzioni studiate per ottimizzare gli ingombri
- Tubo rinforzato con treccia in acciaio (10 m)

General Features

- Two-wheel trolley with tyres, handle and anti-vibrating feet
- 3 Axial stainless steel pistons wobble-plate pump
- Automatic by-pass valve
- Pressure adjustment
- Thermal valve
- Built-in detergent suction
- Powered by RATO petrol engine with low oil level sensor
- Inspectable oil levels
- Discharge plugs and discharge slots to make easy the maintenance and the oil change
- Inspectable water filter
- Space-saving solutions
- Steel braided hose (10 m)

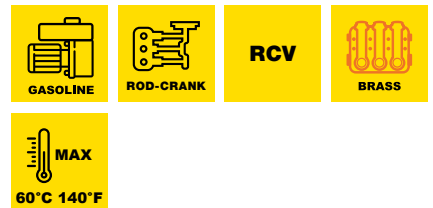

MOD	COD								
		bar max	psi max	l/h max	gph max	rpm	Engine	kW	kg
SUPREME 43	27752	220	3190	720	187	3400	RATO EHR210 - 5,6	4,2	34,7

Accessori standard Standard accessories



47028



3600650



47029 (10 m)



3600400 (low pressure) Nero/Black
 3600350 (0004) Rosso/Red
 3600360 (1504) Giallo/Yellow
 3600380 (4004) Bianco/White



SUPREME 50

ACCESSORI accessories

HEAVYPRO



Caratteristiche Generali

- Carrello completo di manico con due ruote e piedini antivibranti
- Pompa a pistoni con sistema biella-manovella ad elevate prestazioni
- Valvola di by-pass automatica
- Regolazione della pressione
- Valvola termica
- Aspirazione detergente incorporata
- Motorizzato Honda (benzina), con sensore mancanza olio
- Livelli olio ispezionabili
- Tappi ed asole di scarico per agevolare la manutenzione ed il cambio olio
- Filtro acqua ispezionabile
- Soluzioni studiate per ottimizzare gli ingombri
- Tubo rinforzato con treccia in acciaio (10 m)

General Features

- Two-wheel trolley with tyres, handle and anti-vibrating feet
- High performance piston pump with connecting rod system
- Automatic by-pass valve
- Pressure adjustment
- Thermal valve
- Built-in detergent suction
- Powered by Honda petrol engine with low oil level sensor
- Inspectable oil levels
- Discharge plugs and discharge slots to make easy the maintenance and the oil change
- Inspectable water filter
- Space-saving solutions
- Steel braided hose (10 m)

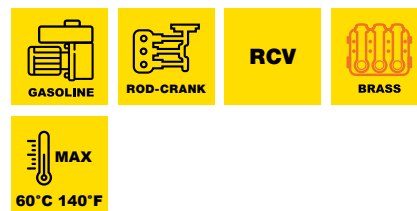

MOD	COD	MAX				MAX				rpm	Engine	kW	KG NET
		bar max	bar work	psi max	psi work	l/h max	l/h work	gph max	gph work				
SUPREME 50	27751	220	160	3150	2320	720	600	190	159	3400	HONDA GP200 - 5,8	4,3	34,7

Accessori standard Standard accessories



47028



3600650



47029 (10 m)



3600400 (low pressure) Nero/Black
 3600930 (00035) Rosso/Red
 3600940 (15035) Giallo/Yellow
 3600960 (40035) Bianco/White



HEAVYPRO



Caratteristiche Generali

- Carrello completo di manico con due ruote pneumatiche gonfiabili e piedini antivibranti
- Pompa a pistoni con sistema biella-manovella ad elevate prestazioni
- Valvola di by-pass automatica
- Regolazione della pressione
- Valvola termica
- Aspirazione detergente incorporata
- Motorizzato RATO (benzina), con sensore mancanza olio
- Livelli olio ispezionabili
- Tappi ed asole di scarico per agevolare la manutenzione ed il cambio olio
- Filtro acqua ispezionabile
- Soluzioni studiate per ottimizzare gli ingombri
- Tubo rinforzato con treccia in acciaio (10 m)
- Funzione autoadescante

General Features

- Two-wheel trolley with handle, inflatable pneumatic wheels and anti-vibrating feet
- High performance piston pump with connecting rod system
- Automatic by-pass valve
- Pressure adjustment
- Thermal valve
- Built-in detergent suction
- Powered by RATO petrol engine with low oil level sensor
- Inspectable oil levels
- Discharge plugs and discharge slots to make easy the maintenance and the oil change
- Inspectable water filter
- Space-saving solutions
- Steel braided hose (10 m)
- Self-priming function

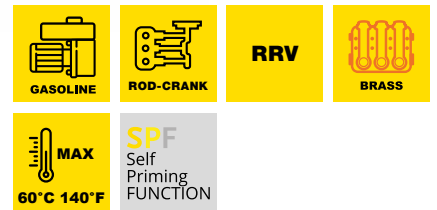

MOD	COD	MAX				MAX				rpm	Engine	kW	kg NET
		bar max	bar work	psi max	psi work	l/h max	l/h work	gph max	gph work				
SUPREME 75	27755	280	230	4060	3335	960	830	254	219	3400	RATO EHR390 - 10,5	7,8	58,4

Accessori standard Standard accessories



47033



3600650



47034 (10 m)



3600400 (low pressure) Nero/Black
 3600350 (0004) Rosso/Red
 3600360 (1504) Giallo/Yellow
 3600380 (4004) Bianco/White



SUPREME 90

ACCESSORI accessories

HEAVYPRO



Caratteristiche Generali

- Carrello completo di manico con due ruote pneumatiche gonfiabili e piedini antivibranti
- Pompa a pistoni con sistema biella-manovella ad elevate prestazioni
- Valvola di by-pass automatica
- Regolazione della pressione
- Valvola termica / Riduttore di giri
- Aspirazione detergente incorporata
- Motorizzato Honda (benzina), con sensore mancanza olio
- Livelli olio ispezionabili, per pompa e riduttore
- Tappi ed asole di scarico per agevolare la manutenzione ed il cambio olio
- Filtro acqua ispezionabile
- Soluzioni studiate per ottimizzare gli ingombri
- Tubo rinforzato con treccia in acciaio (10 m)
- Funzione autoadescante

General Features

- Two-wheel trolley with inflatable tyres, handle and damper feet inflatable pneumatic wheels and anti-vibrating feet
- High performance piston pump with connecting rod system
- Automatic by-pass valve
- Pressure adjustment
- Thermal valve / Gear box
- Built-in detergent suction
- Powered by Honda petrol engine with low oil level sensor
- Inspectable oil levels for pump and gear box
- Discharge plugs and discharge slots to make easy the maintenance and the oil change
- Inspectable water filter
- Space-saving solutions
- Steel braided hose (10 m)
- Self-priming function

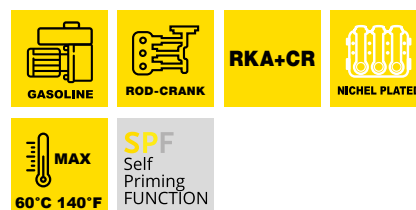

MOD	COD	MAX				MAX						KG NET	
		bar max	bar work	psi max	psi work	l/h max	l/h work	gph max	gph work	rpm	Engine	kW	kg
SUPREME 90	27754	280	230	4060	3335	960	830	254	219	1750	HONDA GX390 - 11,7	8,7	64

Accessori standard Standard accessories



47033



3600650

















47034 (10m)



3600400 (low pressure) Nero/Black
 3600350 (0004) Rosso/Red
 3600360 (1504) Giallo/Yellow
 3600380 (4004) Bianco/White













		5SP		SPARK		VIP REVO			BLITZ	RS		MODENA		
		5SP	70	72	R.613	R.613 K	R.614	R.614 K	B.1510	RS 1510	RS 1815	930	960	980
Pistola Trigger gun		4383516	S											
		47023		S	S	S	S	S						
		46880								S	S	S	S	
		47039												S
		47209							S					
Lancia getto regolabile Lance with adjustable spray nozzle		4821180	S											
		43954 (49 cm)		S										
		43956 (49 cm)			S									
		41929 (56 cm)										S		
		47014 (49 cm)							S					
		41269 (49 cm)				S	S							
		41806 (49 cm)						S	S					
		41747 (49 cm)								S				
		41271 (49 cm)									S			
		46221 (56 cm)										0	S	S











Legenda: "S" Accessorio di serie - "O" Accessorio opzionale
"S" On board accessory - "O" Optional accessory

*** fornita senza ugello, completare con ugello wash nozzle 1/4 MEG /
provided without nozzle, complete with 1/4 MEG nozzle



			5SP		SPARK		VIP REVO			BLITZ		RS		MODENA		
			5SP	70	72	R.613	R.613 K	R.614	R.614 K	B.1510	RS 1510	RS 1815	930	960	980	
Ugello Wash nozzles 1/4 MEG		3086 (15045)												S	S	
		3082 (1504)											0			
Lancia getto rotante Rotary lance		4821190	S													
		40638 (56 cm)			0					0	0					
		40167 (56 cm)				0	0									
		40151 (56 cm)		0				0	0							
		40968 (56 cm)										0	0			
Tubo armato AP HP reinforced hose		4581170	S													
		47024 (8m)		S	S	S		S								
		47025 (10m)					S		S							
		3960970 (10m)								S			S			
		3961050 (10m)									S	S		S	S	
Prolunga tubo Extension hose		46582 (10 m)	0	0	0	0	0	0	0	0	0	0	0	0	0	
		40106 (15m) Raccordo incluso nel kit/Fitting included in kit: M22 x 1,5(M)- 1/4"(M) (1122030)	0	0	0	0	0	0	0	0	0	0	0	0	0	
Spazzola Brush		Fissa / Fixed 43731	0	0	0	0	0	0	0	0	0					
		Rotante / Rotary 43732	0	0	0	0	0	0	0	0						
		Rotante PRO / Rotary PRO 47030									0	0	0	0	0	









Legenda: "S" Accessorio di serie - "O" Accessorio opzionale
"S" On board accessory - "O" Optional accessory

			5SP		SPARK		VIP REVO			BLITZ	RS		MODENA	
			5SP	70	72	R.613	R.613 K	R.614	R.614 K	B.1510	RS 1510	RS 1815	930	960
Kit pulizia tubazioni <i>Pipe drain kit</i> 	43733 (10m)	0												
	43734 (16m)	0												
Kit pulizia tubazioni <i>Pipe drain kit</i> 	1344120 (8m)		0	0	0	0	0	0	0	0	0	0	0	0
	1344130 (16m)		0	0	0	0	0	0	0	0	0	0	0	0
Kit filtro acqua <i>Water filter kit</i> 	43735	0	0	0	0	0	0	0	0	0	0	0	0	0
Filtro acqua ispezionabile <i>Inspectable water filter (pcs 3)</i> 	43736	S	S	S	S	S	S	S	S	0	0	0	0	0
Kit attacco rapido <i>Click fast kit</i> 	43737	0	0	0	0	0	0	0	0	0	0	0	0	0
Kit attacco rapido <i>Click fast kit</i> 	40439	0	0	0	0	0	0	0	0	0	0	0	0	0
Kit schiumogeno <i>Foam lance bottle</i> 	4581160	S												
	43747	0	0	0	0	0	0	0	0	0	0	0	0	0
Kit aspirazione acqua <i>Water suction kit</i> 	43724	0	0	0	0	0	0	0	0	0	0	0	0	0
Kit lancia sabbiante <i>Sandblasting lance kit</i> 	43742		0		0	0	0	0						
	43750	0		0					0	0	0	0	0	0
Sabbia calibrata e filtrata <i>Calibrated, filtered sand</i> 	3207 (5 Kg)	0	0	0	0	0	0	0	0	0	0	0	0	0
	41770 (25 Kg)	0	0	0	0	0	0	0	0	0	0	0	0	0
Kit lancia sottoscocca <i>Underbody lance kit</i> 	40632	0	0		0	0	0	0						
	43744			0								0		
	40635								0			0	0	

Legenda: "S" Accessorio di serie - "O" Accessorio opzionale
 "S" On board accessory - "O" Optional accessory

*** fornita senza ugello, completare con ugello wash nozzle 1/4 MEG /
 provided without nozzle, complete with 1/4 MEG nozzle



		5SP	SPARK		VIP REVO			BLITZ	RS		MODENA			
		5SP	70	72	R.613	R.613 K	R.614	R.614 K	B.1510	RS 1510	RS 1815	930	960	980
Lancia senza ugello <i>Lance without nozzle ***</i>		40652 (RE 90)										0	0	0
		40653 (RE 120)										0	0	0
		40654 (RE 150)										0	0	0
		40694 (RE 170)										0	0	0
		40695 (RE 200)										0	0	0
Lancia doppia <i>Double lance ***</i>		3160620										0	0	0
Ugello bassa pressione <i>Low pressure nozzle</i>		3251 - (2525) <i>(per lancia doppia/for double lance)</i>										0	0	0
Lavapavimenti con serbatoio detergente Ø30cm <i>Patio cleaner with detergent tank Ø30cm</i>		43729	0	0	0	0	0	0	0	0				
Lavapavimenti PRO con regolazione pressione <i>Patio cleaner PRO w. pressure adjustment</i>		46496							0	0	0	0	0	0
Kit adattatori <i>Adapters kit</i>		43745	0	0	0	0	0	0	0	0	0	0	0	0
Kit avvolgitubo senza tubo <i>Hose reel kit without hose</i>		41738	0*	0*		0		0	0*					
		40645								0	0			
		46904										0	0	0
Kit avvolgitubo con tubo AP <i>Hose reel kit with HP hose</i>		41879 (15m)	0*	0*		0		0	0*					

Legenda: "S" Accessorio di serie - "O" Accessorio opzionale - "S" On board accessory - "O" Optional accessory
"O*" in abbinamento con kit carrello 43878/46469 - "O*" To match with trolley kit code 43878/46469

			5SP		SPARK		VIP REVO			BLITZ		RS		MODENA	
			5SP	70	72	R.613	R.613 K	R.614	R.614 K	B.1510	RS 1510	RS 1815	930	960	980
Kit carrello <i>Trolley kit</i>		41869				0	0		0						
		43972		0	0					0					
Kit avvolgitubo senza tubo a muro <i>Wall mounted hose reel without hose kit</i>		41739				0	0	0	0						
		47704		0	0					0					
Kit avvolgitubo a muro con tubo <i>Wall mounted hose reel with hose</i>		41880				0	0	0	0						
		47705		0	0					0					



			10 SERIES						10 SERIES			11 SERIES	SUPREME					
			1003	1003RLW	1005	1007	1007 RLW	1009	1009 RLW	1015	1018	1018H	1120	40	43	50	75	90
Pistola Trigger gun		47039	S	S														
		47209			S	S	S	S	S									
		47033														S	S	
		47023											S					
		47028												S	S			
		41089									S							
Prolunga lancia Lance extension		3600650	S	S									S	S	S	S	S	
		46221			S	S	S	S	S	S		S	0	0	0	0	0	
Lancia con testina alta/bassa senza ugello Lance with high/low pressure head w/out nozzle***		50690									S							
		3961050 (10m)	S		S	S		S										
Tubo armato AP HP reinforced hose		3600970 (15 m)		S			S	S										
		47024 (8m)											S					
		3160590 (10m)							S	S		S						
		47029 (10m)												S	S			
		47034 (10m)														S	S	
		3260590									S							
Tubo aspirazione 100°C Suction hose 100°C		3260600									S							
Ugello Wash nozzles		Bassa pressione / low pressure 3600400 - Nero / Black	S	S									S	S	S	S	S	
		Getto dritto / pencil jet (SS 0035) 3600930 - Rosso / Red											S		S			
		Getto dritto / pencil jet (SS 004) 3600350 - Rosso / Red	S	S										S		S	S	
		Getto ventaglio / fan jet (SS 15035) 3600940 - Giallo / Yellow											S		S			
		Getto ventaglio / fan jet (SS 1504) 3600360 - Giallo / Yellow	S	S										S		S	S	
		Getto ventaglio / fan jet (SS 2504) 3600370 - Verde / Green	S	S														
	Getto ventaglio / fan jet (SS 40035) 3600960 - Bianco / White												S		S			
	Getto ventaglio / fan jet (SS 4004) 3600380 - Bianco / White	S	S											S		S		

*** fornita senza ugello, completare con ugello wash nozzle 1/4 MEG /
provided without nozzle, complete with 1/4 MEG nozzle

Legenda: "S" Accessorio di serie - "O" Accessorio opzionale
"S" On board accessory - "O" Optional accessory



			10 SERIES						10 SERIES			11 SERIES	SUPREME						
			1003	1003RLW	1005	1007	1007 RLW	1009	1009 RLW	1015	1018	1018H	1120	40	43	50	75	90	
Ugello Wash nozzles 1/4 MEG		3195 - (15035)											0*		0*				
		3082 - (1504)	0*	0*										0*		0*	0*		
		3086 - (15045)				S	S			S	S								
		3083 - (1505)			S						S								
		3089 (2506)											S						
		3090-(2507)						S	S										
Kit aspirazione acqua Water suction kit		43724	0	0	0	0	0	0	0	0	0	0	0	0	0	0	0		
Lavapavimenti PRO con regolazione pressione Patio cleaner PRO w. pressure adjustment		46496	0	0	0	0	0		0	0			0	0	0	0	0		
Kit attacco rapido Click fast kit		40439	0	0	0	0	0	0	0	0	0	0	0	0	0	0	0		
15 m Prolunga tubo armato Reinforced extension hose		46850														0	0		
		40106 Raccordo incluso nel kit Fitting included in kit M22 x 1,5(M)-3/8"(M) (1123890)	0	0	0	0	0	0	0	0	0	0	0	0	0	0	0		
Kit lancia sottoscocca Underbody lance kit		43748 (15035)											0		0				
		43744 (1504)	0	0										0		0	0		
		40655 (15045)				0	0			0	0								
		43749(1505)			0						0							0	
		46373 (1506)											0						
41754 (1508)						0	0												
Lancia doppia Double lance ***		3160620	0	0	0	0	0	0	0	0	0	0	0	0	0	0	0		
Ugello bassa pressione Low pressure nozzle		3251 - (2525) (per lancia doppia/for double lance)	0	0	0	0	0	0	0	0	0	0	0	0	0	0	0		
Lancia getto rotante Rotary lance		46635 (56 cm)	0	0															
		40968 (56 cm)			0									0	0	0			
		40964 (56 cm)															0	0	
		40803 (56 cm)				0	0			0	0	0							
		40965 (56 cm)											0						
		40969 (56 cm)						0	0										
Lancia senza ugello Lance without nozzle ***		40652 (RE 90)	0	0	0	0	0	0	0	0	0	0	0	0	0	0	0		
		40653 (RE 120)	0	0	0	0	0	0	0	0	0	0	0	0	0	0	0		
		40654 (RE 150)	0	0	0	0	0	0	0	0	0	0	0	0	0	0	0		
		40694 (RE 170)	0	0	0	0	0	0	0	0	0	0	0	0	0	0	0		
		40695 (RE 200)	0	0	0	0	0	0	0	0	0	0	0	0	0	0	0		

Legenda: "S" Accessorio di serie - "O" Accessorio opzionale

"S" On board accessory - "O" Optional accessory

"O*" in abbinamento con codice 46221 - "O*" To match with code 46221

*** fornita senza ugello, completare con ugello wash nozzle 1/4 MEG /

provided without nozzle, complete with 1/4 MEG nozzle



			10 SERIES						10 SERIES			11 SERIES		SUPREME				
			1003	1003RLW	1005	1007	1007RLW	1009	1009RLW	1015	1018	1018H	1120	40	43	50	75	90
Kit lancia sabbiate <i>Sandblasting lance kit</i>		43750	0	0	0	0	0	0	0	0	0	0	0	0	0	0	0	
		47032			0			0	0			0						
Sabbia calibrata e filtrata <i>Calibrated, filtered sand</i>		3207 (5 Kg)	0	0	0	0	0	0	0	0	0	0	0	0	0	0	0	
		41770 (25 Kg)	0	0	0	0	0	0	0	0	0	0	0	0	0	0	0	
Spazzola rotante <i>Rotary brush</i>		Rotante / Rotary 43732										0						
Spazzola rotante PRO <i>Rotary brush PRO</i>		Rotante PRO / Rotary PRO 47030	0	0	0	0	0		0	0		0		0	0	0	0	
		Rotante PRO / Rotary PRO 47031						0	0									
Kit pulizia tubazioni <i>Pipe drain kit</i>		1344120 (8 m)	0	0	0	0	0		0	0		0	0	0	0	0	0	
		1345870 (8m)						0	0									
		1344130 (16 m)	0	0	0	0	0		0	0		0	0	0	0	0	0	
		1345880 (16m)						0	0									
		1272520 (8m)										0						
		1272530 (16 m)										0						
Kit filtro acqua <i>Water filter kit</i>		43735	0	0	0	0	0	0	0	0		0	0	0	0	0	0	
Filtro acqua ispezionabile <i>Inspectable water filter (pcs 3)</i>		43736	0	0	0	0	0	0	0	0		0	S	S	S	S	S	
Kit attacco rapido <i>Click fast kit</i>		43737	0	0	0	0	0	0	0	0		0	0	0	0	0	0	
Kit adattatori <i>Adapters kit</i>		43745	0	0								0						
Kit avvolgitubo con tubo AP <i>hose reel kit with hp hose</i>		42509	0	S	0	0	S											
		42659					0	S										
		51290							0									
		50272								0	0							
		50273										0						
Kit schiumogeno <i>Foam lance bottle</i>		43747	0	0	0	0	0	0	0	0		0	0	0	0	0	0	

CLEANING DIVISION

LINEA PRO HOT

Pro Hot line

Per utilizzi specifici dove l'acqua calda è un must, le idropultrici Annovi Reverberi con caldaia, soddisfano in pieno le esigenze più estreme di sanificazione e rimozione dello sporco, grazie a prestazioni top di categoria, alla loro tecnologia Made in Italy ed alla loro praticità d'utilizzo.

For specific uses where hot water is a must, Annovi Reverberi high pressure washers with boiler meet the most extreme sanitisation and dirt removal requirements in full, thanks to class-topping performances, Italian technology and very convenient use.

○ LIGHTPRO

Fascia di idropultrici progettate per utilizzatori esperti che hanno necessità di eseguire lavori di pulizia abbastanza frequenti e che richiedono una abbondante riserva di potenza.

High pressure washer category designed for skilled users tackling cleaning quite frequent jobs operations which need plenty of power in reserve.

● HEAVYPRO

Fascia di idropultrici progettate per professionisti che hanno necessità di eseguire lavori di pulizia molto frequenti che richiedono le massime prestazioni.

High pressure cleaner category designed for professionals, dealing with cleaning high frequent jobs that need the very highest-performing appliances.

PRO HOT APPLICATIONS



edilizia
construction



agricoltura
zootecnica
agriculture
zootechny



artigianato
crafts



car wash



automotive



OLIGHTPRO



porta accessori
built-in accessories
holder

manico ergonomico
ergonomic handle

caldaia in acciaio
Stainless steel boiler

battistrada in
gomma
rubber wheels

filtro ingresso acqua
ispezionabile
inspectable water
intake filter

Caratteristiche Generali

- Pompa a 3 pistoni assiali comandati da piattello oscillante
- Pistoni in acciaio inox temprato
- Valvola di by-pass automatica con azzeramento della pressione nella testa della pompa
- Motore elettrico a induzione con protezione termica
- Pressostato di sicurezza per spegnimento della caldaia in caso di mancanza acqua
- Caldaia verticale, doppia serpentina e fondo in materiale refrattario
- Serbatoio gasolio 4 l
- Filtro acqua e filtro aspirazione gasolio
- Tubo rinforzato con treccia in acciaio (8 m)

General Features

- 3 Axial stainless steel pistons wobble-plate pump
- Tempered stainless steel pistons
- Automatic by-pass valve with pump head
- pressure discharge
- Single-phase induction electric motor with thermal protector
- With safety pressure switch to shut down the boiler in case of lack of water
- Vertical boiler with double heating coil and refractory compound base
- Fuel tank capacity 4 l
- Water filter and fuel inlet filter
- Steel braided reinforced hose (8 m)

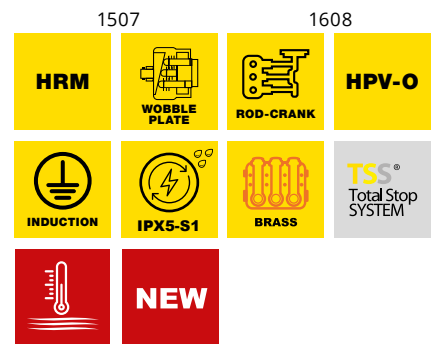

MOD	COD	MAX		MAX		MAX		Hz	V	kg NET	°C Max
		bar max	psi max	l/h max	gph max	kW	rpm				
1507	26412-V	150	2175	450	119	2,4	2800	50	230~	52	90
1608	26413-V	160	2320	500	132	2,5	2800	50	230~	52,8	90

Accessori standard Standard accessories



41047



50690



3164470(8 m)



40320



3729 (1507/15025)
3104 (1608/1503)



HOT 1608 PRO

IDROPULITRICI ALTA PRESSIONE
high pressure washer

O LIGHTPRO



Caratteristiche Generali

- Pompa a 3 pistoni assiali comandati dal piattello oscillante
- Valvola di by-pass automatica con azzeramento della pressione nella testa della pompa
- Motore elettrico monofase con protezione termica
- Pressostato di sicurezza per spegnimento della caldaia in caso di mancanza acqua
- Caldaia verticale in acciaio inox, con sistema di raffreddamento bruciatore a chiocciola azionata da motore elettrico indipendente, doppia serpentina e fondo in cemento refrattario
- Scheda di ritardo per spegnimento caldaia
- Regolazione pressione
- Serbatoio gasolio 8 l, con tappo di scarico
- Termostato
- Aspirazione detergente incorporata
- Filtro acqua e filtro aspirazione gasolio
- Tubo rinforzato con treccia in acciaio (8 m)

General Features

- 3 Axial stainless steel pistons wobble-plate pump
- Automatic by-pass valve with pump head pressure discharge
- Heavy-duty mono-phase motor with thermal protector
- With safety pressure switch to shut down the boiler in case of lack of water
- Stainless steel vertical boiler with coil burner cooling function driven by independent motor, double coil and refractory cement bottom
- Heating boiler shut-down delay circuit
- Pressure adjustment built-in
- Fuel tank with drain plug (8 l)
- Thermostat
- Built-in detergent suction
- Water filter and fuel inlet filter
- Steel braided reinforced hose (8 m)

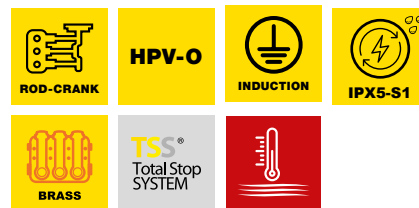

MOD	COD	MAX		MAX		MAX				KG NET	°C Max
		bar max	psi max	l/h max	gph max	kW	rpm	Hz	V	kg	°C
1608 PRO	26415-V	160	2320	500	132	2,5	2800	50	230~	80	100

Accessori standard Standard accessories



41047



46221
(57cm)



3164470 (8m)



3104 (1503)



HEAVYPRO



Spie: tensione, gasolio, fiamma.
Termostato per regolazione temperatura acqua
Warning lights: power on, fuel, flame. Water temperature control thermostat

manico ergonomico
ergonomic handle

caldaia in acciaio
Stainless steel boiler

battistrada in gomma
rubber wheels

filtro ingresso acqua ispezionabile
inspectable water intake filter

Caratteristiche Generali

- Pompa a 3 pistoni assiali comandati dal piattello oscillante
- Valvola di by-pass automatica con azzeramento della pressione nella testa della pompa
- Motore elettrico monofase con protezione termica
- Pressostato di sicurezza per spegnimento della caldaia in caso di mancanza acqua
- Caldaia verticale in acciaio inox, con sistema di raffreddamento bruciatore a chiocciola azionata da motore elettrico indipendente, doppia serpentina e fondo in cemento refrattario
- Scheda di ritardo per spegnimento caldaia
- Regolazione pressione
- Serbatoio gasolio 8 l, con tappo di scarico
- Termostato
- Aspirazione detergente incorporata
- Filtro acqua e filtro aspirazione gasolio
- Tubo rinforzato con treccia in acciaio (10 m)

General Features

- 3 Axial stainless steel pistons wobble-plate pump
- Automatic by-pass valve with pump head pressure discharge
- Heavy-duty mono-phase motor with thermal protector
- With safety pressure switch to shut down the boiler in case of lack of water
- Stainless steel vertical boiler with coil burner cooling function driven by independent motor, double coil and refractory cement bottom
- Heating boiler shut-down delay circuit
- Pressure adjustment built-in
- Fuel tank with drain plug (8 l)
- Thermostat
- Built-in detergent suction
- Water filter and fuel inlet filter
- Steel braided reinforced hose (10 m)

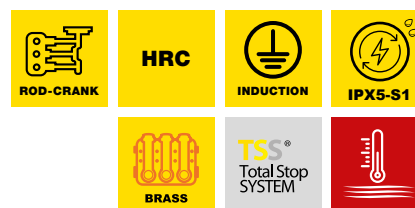

MOD	COD	MAX		MAX		MAX		hp	kW	kW work	rpm	Hz	V	kg NET	°C Max
		bar max	bar work	psi max	psi work	l/h work	gph work								
1510N	15364	150	120	2175	1740	600	159	3	2,2	3	1450	50	230~	82	100

Accessori standard Standard accessories



46203



46221
(57cm)



3160590 (10m)



3082 (1504) (1510N)



HOT 1815

IDROPULTRICI ALTA PRESSIONE high pressure washer

HEAVYPRO



manometro
pressure gauge



manico ergonomico
ergonomic handle



battistrada in
gomma
rubber wheels



termostato per regolazione temperatura acqua
water temperature control thermostat



caldaia in acciaio
stainless steel boiler



telaio in acciaio verniciato
painted steel frame



Caratteristiche Generali

- Pompa a 3 pistoni in ceramica con sistema biella-manovella
- Valvola di by-pass automatica con azzeramento della pressione nella testa della pompa
- Motore elettrico trifase con protezione termica
- Sistema di arresto totale dell'idropultrice a distanza
- Pressostato di sicurezza per spegnimento della caldaia in caso di mancanza acqua
- Caldaia verticale in acciaio inox, con sistema di raffreddamento bruciatore a chiocciola azionata da motore elettrico indipendente
- Scheda di ritardo per spegnimento caldaia
- Regolazione pressione
- Serbatoio gasolio 14 l, con tappo di scarico
- Termostato
- Aspirazione detergente incorporata
- Serbatoio detergente 6 l incorporato
- Filtro acqua e filtro aspirazione gasolio
- Tubo rinforzato con treccia in acciaio (10 m)

General Features

- Triplex pump with ceramic pistons and connecting rod system
- Automatic by-pass valve with pump head pressure discharge
- Heavy-duty three-phase motor with thermal protector
- Remote control for total shut-down of high pressure cleaner
- With safety pressure switch to shut down the boiler in case of lack of water
- Stainless steel vertical boiler with coil burner cooling function driven by independent motor
- Heating boiler shut-down delay circuit
- Pressure adjustment built-in
- Fuel tank with drain plug (14 l)
- Thermostat
- Built-in detergent suction
- Built-in detergent tank capacity 6 l
- Water filter and fuel inlet filter
- Steel braided reinforced hose (10 m)

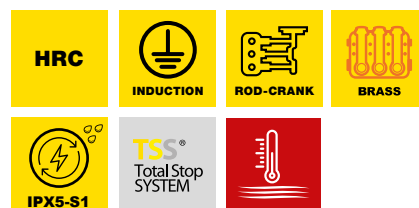

MOD	COD	MAX		MAX		MAX		MAX		MAX		MAX		MAX	
		bar max	bar work	psi max	psi work	l/h work	gph work	hp	kW	kW work	rpm	Hz	V	kg NET	°C Max
1815	15365	180	150	2610	2175	900	238	5,5	4	5	1450	50	400 3~	110	100

Accessori standard Standard accessories



46203



46221
(57 cm)



3160590 (10 m)



3083 (1505)



HEAVYPRO



Caratteristiche Generali

- Pompa a 3 pistoni in ceramica con sistema biella-manovella
- Valvola di by-pass automatica con azzeramento della pressione nella testa della pompa
- Motore elettrico trifase con protezione termica
- Sistema di arresto totale dell'idropulitrice a distanza
- Pressostato di sicurezza per spegnimento della caldaia in caso di mancanza acqua
- Caldaia verticale in acciaio inox, con sistema di raffreddamento bruciatore a chiocciola azionata da motore elettrico indipendente, doppia serpentina e fondo in cemento refrattario
- Scheda micropertite con segnalatore acustico
- Scheda di ritardo per spegnimento caldaia
- Regolazione pressione
- Serbatoio gasolio 15 l, con tappo di scarico
- Termostato
- Aspirazione detergente incorporata
- Serbatoio detergente 4/5 l incorporato
- Filtro acqua e filtro aspirazione gasolio
- Tubo rinforzato con treccia in acciaio (10 m)

General Features

- Triplex pump with ceramic pistons and connecting rod system
- Automatic by-pass valve with pump head pressure discharge
- Heavy-duty three-phase motor with thermal protector
- Remote control for total shut-down of high pressure cleaner
- With safety pressure switch to shut down the boiler in case of lack of water
- Stainless steel vertical boiler with coil burner cooling function driven by independent motor, double coil and refractory cement bottom
- Minor leak detector PCB with buzzer
- Heating boiler shut-down delay circuit
- Pressure adjustment built-in
- Fuel tank with drain plug (15 l)
- Thermostat
- Built-in detergent suction
- Built-in detergent tank capacity 4/5 l
- Water filter and fuel inlet filter
- Steel braided reinforced hose (10 m)

		1815N	2315
		HRC	HRR
		TSS® Total Stop SYSTEM	
NEW			

MOD	COD	MAX		MAX		MAX		MAX		MAX		MAX		MAX	
		bar max	bar work	psi max	psi work	l/h work	gph work	hp	kW	kW work	rpm	Hz	V	kg NET	°C Max
1815N	24400-V	180	150	2200	2175	900	238	5,5	4	5	1450	50	400 3~	110	110
2315	24401-V	230	200	3335	2900	900	238	7,5	5,5	7,4	1450	50	400 3~	120	110

Accessori standard Standard accessories



3164090



46221
(57cm)



3160590 (10m)



3086 (1815N) (15045)
3083 (1505) (2315)



HOT 2321N

IDROPULITRICI ALTA PRESSIONE high pressure washer

HEAVYPRO



Caratteristiche Generali

- Pompa a 3 pistoni in ceramica con sistema biella-manovella
- Valvola di by-pass automatica con azzeramento della pressione nella testa della pompa
- Motore elettrico trifase con protezione termica
- Sistema di arresto totale dell'idropulitrice a distanza
- Pressostato di sicurezza per spegnimento della caldaia in caso di mancanza acqua
- Caldaia verticale in acciaio inox, con sistema di raffreddamento bruciatore a ciocciola azionata da motore elettrico indipendente, doppia serpentina e fondo in cemento refrattario
- Scheda microperdite con segnalatore acustico
- Scheda di ritardo per spegnimento caldaia
- Regolazione pressione
- Serbatoio gasolio 24 l, con tappo di scarico
- Termostato
- Aspirazione detergente incorporata
- Serbatoio detergente 8 l incorporato
- Filtro acqua e filtro aspirazione gasolio
- Tubo rinforzato con treccia in acciaio (10 m)

General Features

- Triplex pump with ceramic pistons and connecting rod system
- Automatic by-pass valve with pump head pressure discharge
- Heavy-duty three-phase motor with thermal protector
- Remote control for total shut-down of high pressure cleaner
- With safety pressure switch to shut down the boiler in case of lack of water
- Stainless steel vertical boiler with coil burner cooling function driven by independent motor, double coil and refractory cement bottom
- Minor leak detector PCB with buzzer
- Heating boiler shut-down delay circuit
- Pressure adjustment built-in
- Fuel tank with drain plug (24 l)
- Thermostat
- Built-in detergent suction
- Built-in detergent tank capacity 8 l
- Water filter and fuel inlet filter
- Steel braided reinforced hose (10 m)

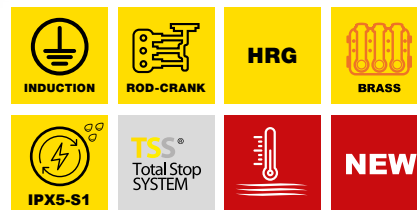

MOD	COD	MAX		MAX		MAX		MAX		MAX		MAX		MAX	
		bar max	bar work	psi max	psi work	l/h work	gph work	hp	kW	kW work	rpm	Hz	V	kg NET	°C Max
2321N	23941-V	230	200	3335	2900	1250	330	9,6	7	9,3	1450	50	400 3~	154	110

Accessori standard Standard accessories



3164090



50690



3160600 (10 m)



3084 (2021N/1506)



HEAVYPRO



quadro comandi
bassa tensione
low voltage
control panel

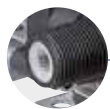

filtro ingresso acqua ispezionabile
inspectable water intake filter



caldaia in acciaio
Stainless steel boiler



porta accessori
built-in accessories
holder



battistrada in
gomma
rubber wheels

Caratteristiche Generali

- Pompa a 3 pistoni in ceramica con sistema biella-manovella
- Valvola di by-pass automatica con azzeramento della pressione nella testa della pompa
- Motore elettrico trifase con protezione termica
- Sistema di arresto totale dell'idropulitrice a distanza
- Pressostato di sicurezza per spegnimento della caldaia in caso di mancanza acqua
- Caldaia verticale in acciaio inox, con sistema di raffreddamento bruciatore a chiocciola azionata da motore elettrico indipendente, doppia serpentina e fondo in cemento refrattario
- Scheda microperdite con segnalatore acustico
- Scheda di ritardo per spegnimento caldaia
- Regolazione pressione
- Serbatoio gasolio 24 l, con tappo di scarico
- Termostato
- Aspirazione detergente incorporata
- Serbatoio detergente 8 l incorporato
- Filtro acqua e filtro aspirazione gasolio
- Pistola con SWIVEL
- Tubo rinforzato con treccia in acciaio (10 m)

General Features

- Triplex pump with ceramic pistons and connecting rod system
- Automatic by-pass valve with pump head pressure discharge
- Heavy-duty three-phase motor with thermal protector
- Remote control for total shut-down of high pressure cleaner
- With safety pressure switch to shut down the boiler in case of lack of water
- Stainless steel vertical boiler with coil burner cooling function driven by independent motor, double coil and refractory cement bottom
- Minor leak detector PCB with buzzer
- Heating boiler shut-down delay circuit
- Pressure adjustment built-in
- Fuel tank with drain plug (24 l)
- Thermostat
- Built-in detergent suction
- Built-in detergent tank capacity 8 l
- Water filter and fuel inlet filter
- Gun with SWIVEL
- Steel braided reinforced hose (10 m)

1310	1320	1325	
HPV	HRC	HRCS	
INDUCTION	ROD-CRANK	IPX5-S1	BRASS
		NEW	
TST® Total Stop SYSTEM TIMED			

MOD	COD	MAX		MAX		MAX		MAX		MAX		MAX		MAX	
		bar max	bar work	psi max	psi work	l/h work	gph work	hp	kW	kW work	rpm	Hz	V	kg NET	°C Max
1310	24894-V	150	130	2200	1885	500	133	2,5	1,8	2,5	2800	50	230~	105	100
1320	25273-V	150	120	2175	1740	600	159	3	2,2	3	1450	50	230~	110	100
1325	25274-V	180	150	2610	2175	900	238	5	3,7	5	2800	50	400 3~	110	100

Accessori standard Standard accessories



47209
(1325)



46221
(57cm)



3160590 (1320.1325) (10 m)
3164640 (1310) (8 m)



3104 (1503) (1310)
3082 (1504) (1320)
3095 (15055) (1325)



HOT 1380N

IDROPULITRICI ALTA PRESSIONE high pressure washer

HEAVYPRO



quadro comandi
bassa tensione
*low voltage
control panel*

filtro ingresso acqua ispezionabile
inspectable water intake filter

caldaia in acciaio
Stainless steel boiler

porta accessori
*built-in accessories
holder*

battistrada in
gomma
rubber wheels



Caratteristiche Generali

- Pompa a 3 pistoni in ceramica con sistema biella-manovella
- Valvola di by-pass automatica con azzeramento della pressione nella testa della pompa
- Motore elettrico trifase con protezione termica
- Sistema di arresto totale dell'idropulitrice a distanza
- Pressostato di sicurezza per spegnimento della caldaia in caso di mancanza acqua
- Caldaia verticale in acciaio inox, con sistema di raffreddamento bruciatore a chiocciola azionata da motore elettrico indipendente, doppia serpentina e fondo in cemento refrattario
- Scheda micropertite con segnalatore acustico
- Scheda di ritardo per spegnimento caldaia
- Regolazione pressione
- Serbatoio gasolio 24 l, con tappo di scarico
- Termostato
- Aspirazione detergente incorporata
- Serbatoio detergente 8 l incorporato
- Filtro acqua e filtro aspirazione gasolio
- Pistola con SWIVEL
- Tubo rinforzato con treccia in acciaio (10 m)

General Features

- Triplex pump with ceramic pistons and connecting rod system
- Automatic by-pass valve with pump head pressure discharge
- Heavy-duty three-phase motor with thermal protector
- Remote control for total shut-down of high pressure cleaner
- With safety pressure switch to shut down the boiler in case of lack of water
- Stainless steel vertical boiler with coil burner cooling function driven by independent motor, double coil and refractory cement bottom
- Minor leak detector PCB with buzzer
- Heating boiler shut-down delay circuit
- Pressure adjustment built-in
- Fuel tank with drain plug (24 l)
- Thermostat
- Built-in detergent suction
- Built-in detergent tank capacity 8 l
- Water filter and fuel inlet filter
- Gun with SWIVEL
- Steel braided reinforced hose (10 m)

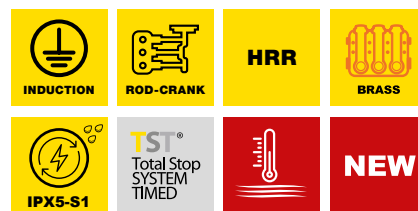

MOD	COD	MAX		MAX		MAX		MAX		MAX		KG NET	°C Max		
		bar max	bar work	psi max	psi work	l/h work	gph work	hp	kW	kW work	rpm	Hz	V	kg	°C
1380N	25284-V	230	200	3335	2900	900	238	7,5	5,5	7,4	1450	50	400 3~	150	110

Accessori standard *Standard accessories*





ANNOVI [®]
REVERBERI
The Power of Experience

ACCESSORI
ACCESSORIES









			HOT											
			1507	1608	1608 PRO	1510N	1815	1815N	2315N	2321N	1310	1320	1325	1380N
Pistola Trigger gun		41047	S	S	S									
		46203				S	S							
		3164090						S	S	S				
		47209									S	S	S	
		47684												S
Lancia con testina fissa senza ugello Lance with fixed head w/ out nozzle		50690	S	S						S				
Lancia con testina alta/ bassa senza ugello Lance with high/low pressure head w/out nozzle***		46221			S	S	S	S	S		S	S	S	S
Tubo armato AP 8 m Reinforced HP hose 8 m		3164470 (8m)	S	S	S									
		3164640 (8m)									S			
		3160600 (10m)								S				
		3160590 (10m)				S	S	S	S			S	S	S
Kit schiumogeno con serbatoio Foam lance bottle kit *		40320	S	S										

Legenda: "S" Accessorio di serie - "O" Accessorio opzionale
"S" On board accessory - "O" Optional accessory

***Utilizzare solo con acqua fredda**
Use with cold water only

***** fornita senza ugello, completare con ugello wash nozzle 1/4 MEG /**
provided without nozzle, complete with 1/4 MEG nozzle













		HOT											
		1507	1608	1608 PRO	1510N	1815	1815N	2315N	2321N	1310	1320	1325	1380N
Ugello Wash nozzle		3729 - (15025)	S										
		3104 - (1503)		S S						S			
		3082 - (1504)			S						S		
		3086 - (15045)						S					S
		3083 - (1505)				S S							
		3095 (15055)										S	
		3084 - (1506)							S				
	Spazzola Brush*		Fissa / Fixed 43731	0	0	0							
		Rotante / Rotary 43732	0	0	0								
Kit pulizia tubazioni Pipe drain kit		1272520 (8 m)	0	0	0	0	0	0	0	0	0	0	0
		1272530 (16 m)	0	0	0	0	0	0	0	0	0	0	0
Kit aspirazione acqua Water suction kit *		43724	0	0	0	0	0	0		0	0	0	0
Kit attacco rapido Click fast kit		40439	0	0	0	0	0	0	0	0	0	0	0
Ugello a vapore Steam nozzle		50250	0	0	0	0	0	0	0	0	0	0	0
Kit lancia sottoscocca Underbody lance kit *		40631 (15025)	0										
		40632 (1503)		0 0						0			
		43749 (1505)				0 0							
		43376 (1506)							0			0	
		43744 (1504)			0						0		
		40655 (15045)						0					0

*Utilizzare solo con acqua fredda
Use with cold water only

*** fornita senza ugello, completare con ugello wash nozzle 1/4 MEG /
provided without nozzle, complete with 1/4 MEG nozzle





Legenda: "S" Accessorio di serie - "O" Accessorio opzionale
"S" On board accessory - "O" Optional accessory

			HOT													
			1507	1608	1608 PRO	1510N	1815	1815N	2315N	2321N	1310	1320	1325	1380N		
Kit schiumogeno <i>Foam lance bottle *</i>		43747	0	0	0	0	0	0	0	0	0	0	0	0		
Kit filtro acqua <i>Water filter kit</i>		43735	0	0	0	0	0	0	0	0	0	0	0	0		
Kit lancia sabbiate <i>Sandblasting lance kit *</i>		43742	0	0	0						0					
		43750				0			0			0		0		
Kit lancia sabbiate <i>Sandblasting lance kit *</i>		47032					0	0		0			0			
Sabbia calibrata e filtrata <i>Calibrated, filtered sand</i>		3207 (5 Kg)	0	0	0	0	0	0	0	0	0	0	0	0		
Sabbia calibrata e filtrata <i>Calibrated, filtered sand</i>		41770 (25 Kg)	0	0	0	0	0	0	0	0	0	0	0	0		
Kit avvolgitubo senza tubo <i>Hose reel kit without hose</i>		42660	0	0												
Lancia senza ugello <i>Lance without nozzle ***</i>		40840					0	0	0	0						
		40652 (RE 90)	0	0	0	0	0	0	0	0	0	0	0	0	0	
		40653 (RE 120)	0	0	0	0	0	0	0	0	0	0	0	0	0	
Lancia senza ugello <i>Lance without nozzle ***</i>		40654 (RE 150)	0	0	0	0	0	0	0	0	0	0	0	0		
		40694 (RE 170)	0	0	0	0	0	0	0	0	0	0	0	0	0	
Lancia senza ugello <i>Lance without nozzle ***</i>		40695 (RE 200)	0	0	0	0	0	0	0	0	0	0	0	0		
Lancia doppia senza ugello <i>Double lance w/out nozzle ***</i>		3160620	0	0	0	0	0	0	0	0	0	0	0	0		

Legenda: "S" Accessorio di serie - "O" Accessorio opzionale
"S" On board accessory - "O" Optional accessory

***Utilizzare solo con acqua fredda**
Use with cold water only



			HOT											
			1507	1608	1608 PRO	1510N	1815	1815N	2315N	2321N	1310	1320	1325	1380N
Ugello bassa pressione <i>Low pressure nozzle</i>		3251 - (2525) (per lancia doppia/ for double lance)	0	0	0	0	0	0	0	0	0	0	0	0
		40898	0											
Lancia getto rotante <i>Rotary lance</i>		41050		0	0						0			
		40803												0
		40965						0					0	
		40966					0	0						
		40969								0				
		40964				0						0		
		40967												
15 m Prolunga tubo armato AP <i>Extension HP reinforced hose</i>		(PN 250bar) (40106) Raccordo M22x1,5(M)-3/8"(M) incluso nel kit / included in kit / (1123890)	0	0	0	0	0	0	0	0	0	0	0	0
		43729	0	0	0	0								
Lavapavimenti con serbatoio detergente Ø30cm <i>Patio cleaner with detergent tank Ø30cm</i>		46497	0	0	0	0					0			
		46496					0	0	0			0	0	0

*Utilizzare solo con acqua fredda
Use with cold water only

*** fornita senza ugello, completare con ugello wash nozzle 1/4 MEG /
provided without nozzle, complete with 1/4 MEG nozzle

Legenda: "S" Accessorio di serie - "O" Accessorio opzionale
"S" On board accessory - "O" Optional accessory

ASPIRACENERE E ASPIRATORI CASA

*Ash & vacuum
cleaners home*

HOME APPLICATIONS



cancellate
fencing



panchine
benches



giardino
garden



biciclette
bicycles



moto
motorcycle



auto
cars



camper
recreational
vehicles RV's,
campers



barche
boats



pavimenti
flooring,
paving
stones



scale
stairs



piscine
pools



utensili
tools



casa
house



muri
walls



tetti
roofs

Compatti ma estremamente potenti e versatili. Studiati anche per la pulizia di piccoli spazi, gli aspiratori multiuso ANNOVI REVERBERI sono la soluzione ideale per diversi tipi di sporco, sia esso solido e liquido. Rumorosità controllata e accessori pratici sono gli ingredienti perfetti per prenderti cura degli spazi a te più cari con estrema praticità.

Compact but extremely powerful and versatile. Designed for cleaning even small spaces, ANNOVI REVERBERI multi-purpose vacuum cleaners are the ideal solution for different types of both solid and liquid dirt. Controlled noise levels and handy accessories are the perfect ingredients for taking care of the spaces you love with the greatest of ease.

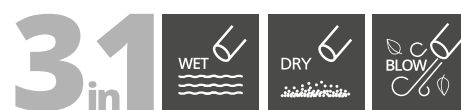

funzione soffiante
blower function



fusto raccolta in
materiale plastico
plastic tank



cerniere aggancio/sgancio
rapido per pulizia filtri e fusto
*quick connection/release hinges
for filter and tank cleaning*



4 ruote pivotanti e stabili
4 stable castor wheels



Caratteristiche Generali

- Aspiratore per liquidi e polveri
- Fusto raccolta in materiale plastico robusto e resistente
- Tubo d'aspirazione flessibile e resistente alla torsione
- Portaccessori integrato
- Posizione parcheggio durante le soste di lavoro
- Gancio per rimessaggio cavo d'alimentazione
- Galleggiante per interrompere l'aspirazione quando il fusto è pieno
- Cerniere aggancio-sgancio rapido per pulizia filtri e fusto
- Funzione soffiante
- Filtro alta efficienza lavabile
- Cavo elettrico di 2,5 metri

General Features

- Wet & Dry vacuum cleaner
- Tough, sturdy plastic tank
- Flexible, kink-resistant suction hose
- Integral accessories carrier
- Parking position for use during breaks in work
- Hook for stowing power supply cable
- Float switch to cut out suction when tank is full
- Quick connection/release hinges for filter and tank cleaning
- Blower function
- Washable high efficiency filter
- 2,5m power cord



MOD	COD					
		K ^P A	l/s	W(Max)	Hz	V
WD 15	51934-V	17	28	1200	50-60	220-240~



dB(A)	l	kg
73,6	15	5.4

Accessori standard Standard accessories



4340150 4341870 (1,5m) 4340200
46548 46556 4340170



WD 25

ASPIRATORI SOLIDI LIQUIDI wet & dry vacuum cleaners

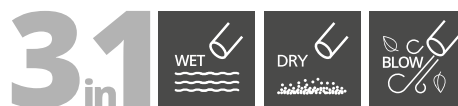

funzione soffiante
blower function



cerniere aggancio/sgancio
rapido per pulizia filtri e fusto
*quick connection/release hinges
for filter and tank cleaning*



fusto raccolta in
materiale plastico
plastic tank



4 ruote pivotanti e stabili
4 stable castor wheels

Caratteristiche Generali

- Aspiratore per liquidi e polveri
- Fusto raccolta in materiale plastico robusto e resistente
- Tubo d'aspirazione flessibile e resistente alla torsione
- Portaccessori integrato
- Posizione parcheggio durante le soste di lavoro
- Gancio per rimessaggio cavo d'alimentazione
- Galleggiante per interrompere l'aspirazione quando il fusto è pieno
- Cerniere aggancio-sgancio rapido per pulizia filtri e fusto
- Funzione soffiante
- Filtro alta efficienza lavabile
- Cavo elettrico di 2,5 metri

General Features

- Wet & Dry vacuum cleaner
- Tough, sturdy plastic tank
- Flexible, kink-resistant suction hose
- Integral accessories carrier
- Parking position for use during breaks in work
- Hook for stowing power supply cable
- Float switch to cut out suction when tank is full
- Quick connection/release hinges for filter and tank cleaning
- Blower function
- Washable high efficiency filter
- 2,5m power cord



MOD	COD			
WD 25	51935-V	17	28	1200

KPA	l/s	W(MAX)	Hz	V
17	28	1200	50-60	220-240-



dB(A)	l	kg
73,6	25	5.6

Accessori standard Standard accessories



4340150

4341870 (1,5m)

4340200



46549



46557



4340170



3_{in}1



Caratteristiche Generali

- Aspiratore per liquidi e polveri
- Fusto raccolto in materiale plastico robusto e resistente
- Tubo d'aspirazione flessibile e resistente alla torsione
- Portaccessori integrato
- Posizione parcheggio durante le soste di lavoro
- Gancio per rimessaggio cavo d'alimentazione
- Galleggiante per interrompere l'aspirazione quando il fusto è pieno
- Cerniere aggancio-sgancio rapido per pulizia filtri e fusto
- Funzione soffiante
- Sacchetto filtro carta + filtro in spugna
- Cavo elettrico di 5 metri

General Features

- Wet & Dry vacuum cleaner
- Tough, sturdy plastic tank
- Flexible, kink-resistant suction hose
- Integral accessories carrier
- Parking position for use during breaks in work
- Hook for stowing power supply cable
- Float switch to cut out suction when tank is full
- Quick connection/release hinges for filter and tank cleaning
- Blower function
- Paper filter bag + sponge filter
- 5m power cord



MOD	COD						
		K ^P A	l/s	STADI STAGES	W(Max)	Hz	V
WD 30X	52085	19	37	1	1600	50-60	220-240~



dB(A)	l	kg
74	30	6,5

Accessori standard Standard accessories





WD 35T

ASPIRATORI SOLIDI LIQUIDI wet & dry vacuum cleaners

4 in 1



Caratteristiche Generali

- Aspiratore per liquidi e polveri
- Fusto raccolto in materiale plastico robusto e resistente
- Tubo d'aspirazione flessibile e resistente alla torsione
- Portaccessori integrato
- Posizione parcheggio durante le soste di lavoro
- Gancio per rimessaggio cavo d'alimentazione
- Galleggiante per interrompere l'aspirazione quando il fusto è pieno
- Cerniere aggancio-sgancio rapido per pulizia filtri e fusto
- Funzione soffiante
- Sacchetto filtro carta + filtro in spugna
- Cavo elettrico di 5 metri

General Features

- Wet & Dry vacuum cleaner
- Tough, sturdy plastic tank
- Flexible, kink-resistant suction hose
- Integral accessories carrier
- Parking position for use during breaks in work
- Hook for stowing power supply cable
- Float switch to cut out suction when tank is full
- Quick connection/release hinges for filter and tank cleaning
- Blower function
- Paper filter bag + sponge filter
- 5m power cord



MOD	COD						
		K ^{PA}	l/s	STADI STAGES	W(Max)	Hz	V
WD 35T	52086	19	39	1	1600	50-60	220-240~



dB(A)	l	kg
74	35	9.9

Accessori standard Standard accessories





4 in 1



Caratteristiche Generali

- Aspiratore per liquidi e polveri
- Fusto raccolta in acciaio inox robusto e resistente
- Tubo d'aspirazione flessibile e resistente alla torsione
- Portaccessori integrato
- Posizione parcheggio durante le soste di lavoro
- Gancio per rimessaggio cavo d'alimentazione
- Galleggiante per interrompere l'aspirazione quando il fusto è pieno
- Cerniere aggancio-sgancio rapido per pulizia filtri e fusto
- Funzione soffiante
- Sacchetto filtro carta + filtro in spugna
- Cavo elettrico di 2,5 metri

General Features

- Wet & Dry vacuum cleaner
- Tough, sturdy stainless steel tank
- Flexible, kink-resistant suction hose
- Integral accessories carrier
- Parking position for use during breaks in work
- Hook for stowing power supply cable
- Float switch to cut out suction when tank is full
- Quick connection/release hinges for filter and tank cleaning
- Blower function
- Paper filter bag + sponge filter
- 2,5m power cord



MOD	COD						
		K ^P A	l/s	STADI STAGES	W(Max)	Hz	V
WD 50XT	52087-V	19	41	1	1600	50-60	220-240~



dB(A)	l	kg
74	50	13,8

Accessori standard Standard accessories





AR20M

ASPIRATORI SOLIDI LIQUIDI wet & dry vacuum cleaners



funzione soffiante
blower function



fusto raccolta in acciaio inox
stainless steel tank



cerniere aggancio/sgancio
rapido per pulizia filtri e fusto
*quick connection/release hinges
for filter and tank cleaning*



4 ruote pivotanti e stabili
4 stable castor wheels



Caratteristiche Generali

- Aspiratore per ceneri, liquidi e polveri
- Fusto raccolta in acciaio inossidabile
- Tubo d'aspirazione flessibile e resistente alla torsione e tubo aspirazione flessibile in metallo rivestito
- Portaccessori integrato
- Posizione parcheggio durante le soste di lavoro
- Gancio per rimessaggio cavo d'alimentazione
- Galleggiante per interrompere l'aspirazione quando il fusto è pieno
- Cerniere aggancio-sgancio rapido per pulizia filtri e fusto
- Funzione soffiante
- Filtro alta efficienza lavabile
- Cavo elettrico di 5 metri

General Features

- Ash, Wet & Dry vacuum cleaner
- Stainless steel tank
- Flexible, kink-resistant suction hose and Metal coated flexible suction hose for ash
- Integral accessories carrier
- Parking position for use during breaks in work
- Hook for stowing power supply cable
- Float switch to cut out suction when tank is full
- Quick connection/release hinges for filter and tank cleaning
- Blower function
- Washable high efficiency filter
- 5 m power cord



MOD	COD						
		KPA	l/s	W(MAX)	Hz	V	
AR20M	52014	17	28	1200	50-60	220-240~	



dB(A)	l	kg
73,6	20	6.1

Accessori standard Standard accessories



4341680 4341700 (1,2m) 4341710



4340150 4340180 4341310 (2m)



4340200 4341690 4340170

CLEANING **DIVISION**

ASPIRATORI PRO

Vacuum cleaners Pro

PRO APPLICATIONS



edilizia
construction



agricoltura
zootecnica
agriculture
zootechny



artigianato
crafts



car wash



automotive

Gamma tecnicamente progettata per l'aspirazione di liquidi e solidi, utilizzata quotidianamente dai migliori professionisti ed artigiani. Silenziosi e pratici raccolgono con estrema facilità lo sporco, lasciando le superfici di lavoro pulite e l'ambiente circostante sano.

Range engineered for the vacuum cleaning of liquids and solids, used very day by top professionals and craftsmen. Quiet and convenient, they pick up dirt effortlessly, leaving work surfaces clean and the surrounding environment healthy.



WD 76/2

ASPIRATORI SOLIDI LIQUIDI wet & dry vacuum cleaners



Caratteristiche Generali

- Modello professionale compatto dedicato all'aspirazione di polveri e liquidi
- Fusto in acciaio inox
- Motori bi-stadio
- Galleggiante per interrompere l'aspirazione quando il fusto è pieno
- Cerniere aggancio/sgancio rapido per pulizia filtri e fusto
- Tubo d'aspirazione resistente alla torsione
- Ruote pivotanti antitraccia
- Porta accessori integrato

General Features

- Professional dust and liquid vacuum cleaner
- Stainless steel body
- Two-stage motors
- Float switch to cut out suction when tank is full
- Quick connection/release hinges for filter and tank cleaning
- Kink-resistant suction hose
- No markings pivoting wheels
- Built-in accessory holder



MOD	COD								
		K ^P A	l/s	N°	STADI STAGES	W(MAX)	W	Hz	V
WD 76/2	52586	22,1	94,5	2	2	2400	2050	50	230~



dB(A)	l	kg
67	77	24

Accessori standard Standard accessories





Caratteristiche Generali

- Modello professionale compatto dedicato all'aspirazione di polveri e liquidi
- Fusto in acciaio inox
- Motori bi-stadio
- Galleggiante per interrompere l'aspirazione quando il fusto è pieno
- Cerniere aggancio/sgancio rapido per pulizia filtri e fusto
- Tubo d'aspirazione resistente alla torsione
- Ruote pivotanti antitraccia
- Porta accessori integrato

General Features

- Professional dust and liquid vacuum cleaner
- Stainless steel body
- Two-stage motors
- Float switch to cut out suction when tank is full
- Quick connection/release hinges for filter and tank cleaning
- Kink-resistant suction hose
- No markings pivoting wheels
- Built-in accessory holder



MOD	COD									
		K ^{PA}	l/s	N°	STADI STAGES	W(MAX)	W	Hz	V	
WD 76/3	52587	22,1	141,7	3	2	3300	2900	50	230~	



dB(A)	l	kg
68	77	29

Accessori standard Standard accessories





ACCESSORI SPECIALI

SPECIAL ACCESSORIES

ACCESSORIO 3 IN 1

SIDEKICK PRO

Cod. 51959

L'accessorio 3 in 1 ANNOVI REVERBERI è un aiuto nei lavori di bricolage domestici. Ha una tripla funzione: sorregge piccole mensole o listelli; permette di regolarne l'altezza grazie al supporto rotante a 360°; raccoglie la polvere di fori da trapano su pareti e soffitti.

ANNOVI REVERBERI Sidekick Pro accessory is an helpful tool in domestic and DIY works. It has a triple function: supports small shelves or strips; allows you to adjust the height thanks to the 360° rotating support; collects dust from drill holes on walls and ceilings.





RACCOGLIPOLVERE DA FORATURA

DRILLDUST COLLECTOR

Cod. 51853

L'accessorio raccogli-polvere da foratura per aspiratori solidi e liquidi ANNOVI REVERBERI permette di raccogliere la polvere generata dall'utilizzo di trapani e avvitatori.

DrillDust Collector accessory for ANNOVI REVERBERI solid and liquid vacuum cleaners allows to collect the dust from drills and screwdrivers.

VENTOSA STURATUBI











DRAIN UNBLOCKER









Cod. 51959

L'accessorio ventosa sturatubi per aspiratori solidi e liquidi ANNOVI REVERBERI consente di liberare e ripulire gli scarichi intasati. Grazie alla potenza dell'aspirazione garantisce una pulizia profonda senza residui. L'innovativo design permette l'aderenza a tutte le tipologie di scarichi.

The Drain Unblocker accessory for ANNOVI REVERBERI solid and liquid vacuum cleaners allows you to free and clean up clogged drains. Thanks to the suction power guarantees a deep cleaning without residues. The innovative design allows adherence to all kind of drains.













		WD 15	WD 25	WD 30X	WD 35T	WD 50XT	WD 76/2	WD 76/3	AR 20M
Spazzola per pavimenti secco/umido <i>Floor wet&dry brush</i>		50209 (ø37)					0	0	
		4340150 (ø35)	S	S	S	S			S
Spazzola per pavimenti per umido <i>Brush for wet floor</i>		4341330				S			
		4341430 (ø35)	0	0	0	0			0
		50210 (ø37)					0	0	
Corpo spazzola <i>nozzle body</i>		52517 (ø40)					S	S	
Inserto spazzola pavimenti per umido <i>Wet floor brush insert</i>		51091 (ø40)					S	S	
Inserto spazzola pavimenti per secco <i>Dry floor brush insert</i>		51090 (ø40)					S	S	
Spazzola combinata in plastica per pavimenti <i>Combined plastic floor brush</i>		4341340 (ø35) solo secco <i>dry only</i>	0	0	0	0			0
Spazzola combinata con inserto metallico per pavimenti <i>Combined metal floor brush</i>		4340750 (ø40) solo secco <i>dry only</i>	0	0	0	0			0
Spazzola combinata con inserto metallico per pavimenti (solo secco) <i>Combined metal floor brush (only dry)</i>		4341370 (ø40) solo secco <i>dry only</i>					0		
Spazzola per pavimenti combinata solo secco <i>Combined floor brush dry only</i>		46546 (ø35)	0	0	0	0			0
Spazzola per pulizia tappeti e poltrone <i>Carpet and upholstery brush</i>		4340180 (ø35)	0	0	S	S			S
Spazzola rotonda <i>Round brush</i>		46547 (ø35)	0	0	0	0			0
		4341370 (ø40)					0		
		52504 (ø40)					S	S	

			ACCESSORI OPZIONALI							optional accessories	
			WD 15	WD 25	WD 30X	WD 35T	WD 50XT	WD 76/2	WD 76/3	AR 20M	
Bocchetta per fessure <i>Crevice nozzle</i>		4340170 (ø35)	S	S	S	0				S	
Bocchetta grande per fessure <i>Wide crevice nozzle</i>		4340730 (ø35)				S					
		50203 (ø40)						S	S		
Bocchetta per superfici secco/umido <i>Wet&dry nozzle</i>		4340740 (ø40)					0				
Ventosa sturatubi <i>Suction cup drain unblocker</i>		51957	0	0	0	0	0			0	
Raccogli polvere da foratura <i>Drilldust collector</i>		51853	0	0	0	0	0			0	
Accessorio 3in1 <i>Sidekick Pro 3in1</i>		51959	0	0	0	0	0			0	
Tubo di aspirazione con gomito 1,5m <i>Suction hose with elbow 1,5m</i>		4340870 (ø35)	S	S							
Tubo di aspirazione con gomito 2m <i>Suction hose with elbow 2m</i>		4340140 (ø35)			S						
Tubo di aspirazione con gomito 2m <i>Suction hose with elbow 2m</i>		4341310 (ø35)	0	0		S				S	
Tubo di aspirazione con gomito 2m <i>Suction hose with elbow 2m</i>		4341320 (ø40)					S				
Tubo di aspirazione con gomito 5m <i>Suction hose with elbow 5m</i>		4341780 (ø35)	0	0	0	0					
Tubo di aspirazione con gomito 5m <i>Suction hose with elbow 5m</i>		4341790 (ø40)					0				
Tubo di aspirazione con gomito 10m <i>Suction hose with elbow 10m</i>		4341800 (ø35)	0	0	0	0					
Tubo di aspirazione con gomito 10m <i>Suction hose with elbow 10m</i>		43415810 (ø40)					0				
Tubo di aspirazione con gomito 2,5m <i>Suction hose with elbow 2,5m</i>			50202						S	S	
Tubo in metratura <i>Hose supplied by the metre</i>			51115 (ø40/15 m)						0	0	
	51391 (ø40/30 m)							0	0		

			WD 15	WD 25	WD 30X	WD 35T	WD 50XT	WD 76/2	WD 76/3	AR 20M	
Tubo prolunga plastica Plastic suction tube		51207 (ø40)						0	0		
Tubo rigido di aspirazione in plastica Plastic suction tube		4340200 (ø35/3x330 mm)	S	0						S	
		4340210 (ø35/2x470 mm)	0	S						0	
		4340230 (ø35/2x470 mm)	0	0	0					0	
Tubi rigidi di aspirazione in metallo Metal suction tubes		4341880 (ø40/2x480 mm)					S				
		4340230 (ø35/2x470 mm)				S					
Tubi di aspirazione in metallo (500mm) Metal suction tubes (500mm)		50205 (ø40)						S	S		
		50206						S	S		
Tubo telescopico in acciaio inossidabile Stainless steel telescopic tube		4340240 (ø35/480-780mm)	0	0	0	0				0	
Bocchetta per fessure Crevice nozzle		4341350 (ø40)					S				
Adattatore per elettro utensili Adapter for power tools		4340340 (ø46)	0	0	0	S	S			0	
Kit terminali per tubo in metatura End piece kit for hose supplied by metre		51176 (ø40)						0	0		
Dispositivo anti schiuma Anti foam device		50277						0	0		
Aspiraliquidi Liquid vacuum		51474						0	0		
Sacchetto filtro carta Paper filter bag		46548 (15 l/5 pcs)	S								
		46646 (20 l/5 pcs)								0	
		46549 (30 l/5 pcs)		S	S						
		46550 (35 l/5 pcs)				S					
		46551 (50 l/5 pcs)					S				
		51082 (77 l/5 pcs)							0	0	

Legenda: "S" Accessorio di serie - "O" Accessorio opzionale
"S" On board accessory - "O" Optional accessory



			WD 15	WD 25	WD 30X	WD 35T	WD 50XT	WD 76/2	WD 76/3	AR 20M
Filtro in poliestere <i>Polyester filter</i>		51071 (77 l/5 pcs)							0	
Filtro stoffa lavabile <i>Washable fabric filter bag</i>		46647 (20 l/2 pcs)								0
		46553 (30 l/2 pcs)		0	0					
		46554 (35 l/2 pcs)				0				
		46555 (50 l/2 pcs)					0			
Filtro in spugna <i>Sponge filter</i>		46556 (5 pcs)	S							
		46557 (5 pcs)		S	0	0	0			
		4341690 (1 pc)								S
Filtro alta efficienza plissettato con protezione metallica <i>High efficiency pleated filter with metal guard</i>		4341680 (h= 115 mm)								S
Filtro cartuccia ad alta efficienza <i>High efficiency cartridge</i>		46558 (h= 91 mm)	0							
		46559 (h= 115 mm)		0	S	S	S			0
Filtro in poliestere <i>Polyester filter</i>		50368						S	S	
Filtro spugna per liquidi <i>Sponge filter for wet uses</i>		51070						S	S	
Filtro cartuccia <i>Cartridge filter</i>		50233 (ø250)						0	0	
Tubo in alluminio <i>Aluminum suction tube</i>		4341710 (ø34mm/23 cm)								S
Prefiltro in tessuto ritardante <i>Fire retardant prefilter</i>		4520120								0
Filtro in nylon <i>Nylon filter</i>		51072 (ø44)						0	0	

Legenda: "S" Accessorio di serie - "O" Accessorio opzionale
"S" On board accessory - "O" Optional accessory

POMPE AUTOADESCANTI SENZA E CON AUTOCLAVE

*Self-priming pumps without
and with booster unit*

SENZA AUTOCLAVE

Le pompe autoadescenti della gamma Annovi Reverberi forniscono la condizione ideale per una crescita rigogliosa delle piante e garantisce una conveniente fornitura di acqua di servizio per la casa e il giardino. Consentono il recupero dell'acqua attingendo da fonti alternative come pozzi o bacini, per sistemi di irrigazione fissi o mobili, oppure per riempire piscinette o fontane. Grazie al sistema di risparmio energetico ON/OFF, le pompe offrono una soluzione sostenibile e rispettosa dell'ambiente.

WITHOUT BOOSTER UNIT

Annovi Reverberi's self-priming jet pumps range provides the ideal condition for the lush growth of the garden plants and grants a convenient service water supply for home and garden. It allows water recycling especially useful for fixed or mobile irrigation systems or to fill small pools or fountains, by drawing from alternative sources such as wells or basins. Thanks to the energy saving ON / OFF system, the pumps offer a sustainable and environment friendly solution.

CON AUTOCLAVE

Le pompe autoadescenti con autoclave della serie Annovi Reverberi forniscono acqua da utilizzare con elettrodomestici, sanitari o per l'irrigazione del giardino, mantenendo una pressione stabile e costante. Le pompe si integrano con l'approvvigionamento idrico domestico, per l'utilizzo dell'acqua piovana, di serbatoi o di pozzi, evitando lo spreco di acqua potabile. Grazie al sistema di risparmio energetico ON/OFF, queste pompe offrono una soluzione sostenibile e rispettosa dell'ambiente.

WITH BOOSTER UNIT

The self-priming pumps with pressure tank, provided by Annovi Reverberi, excel at supplying water for domestic clean water fixtures or for garden irrigation, maintaining a stable and constant pressure. The pumps can be integrated with domestic water supply systems, since their use of rainwater, drawn from tanks or wells, prevents the waste of drinking water. Thanks to the energy saving ON/OFF system, the pumps offer a sustainable and environment friendly solution.

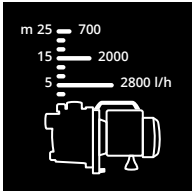
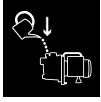

sistema di riempimento
filling system

impugnatura ergonomica
hand grip handle

sistema di svuotamento rapido
quick emptying system



Caratteristiche Generali

- La portata max. da 3100 l/h offre alte prestazioni
- Basso consumo energetico
- Autoadescante
- Protezione motore dalle alte temperature

General Features

- 3100 l/h max. flow rate offers high performance
- Low power consumption
- Self priming
- Motor protection at high temperatures

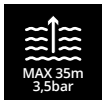

MOD	COD					
		V	Hz	W	m	l/h
PG3100P	52054	230~	50	600	35	3100

T(Max)	IP X	kg
35°C	4	6,3

Accessori opzionali Optional accessories



46489
(7 m)



46491
(1 l)



PG4600X

POMPE AUTOADESCANTI
self-priming pumps

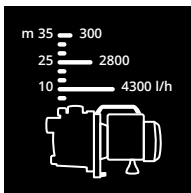

Caratteristiche Generali

- La portata max. da 4600 l/h offre alte prestazioni
- Motore performante
- Protezione motore dalle alte temperature

General Features

- 4600 l/h max. flow rate offers high performance
- Powerful motor
- Motor protection at high temperatures



MOD	COD					
		V	Hz	W	m	l/h
PG4600X	52056	230~	50	1100	45	4600

T(Max)	IP X	kg
35°C	4	9,1

Accessori opzionali Optional accessories



46489
(7 m)



46491
(1 l)

PG3100PB

POMPE AUTOADESCANTI
CON AUTOCLAVE
self-priming pumps with booster unit

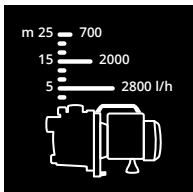
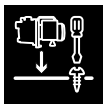

riempimento
pompa facilitato
pump easy fill

impugnatura
ergonomica
hand grip handle

ON/OFF automatico
automatic ON/OFF



Caratteristiche Generali

- La portata max. da 3100 l/h offre alte prestazioni
- Serbatoio 19L in acciaio al carbonio
- Interruttore automatico ON/OFF
- Protezione motore dalle alte temperature

General Features

- 3100 l/h max. flow rate offers high performance
- 19L carbon steel pressure tank
- Automatic ON/OFF switch
- Motor protection at high temperatures

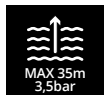

MOD	COD					
		V	Hz	W	m	l/h
PG3100PB	52055	230~	50	600	35	3100

T(Max)	IP X	kg
35°C	4	10,8

Accessori opzionali Optional accessories



46489
(7 m)



46492
(2 l)

A richiesta fino a esaurimento scorte /
On request - available until stock runs out

POMPE AD IMMERSIONE

Submersible pumps

Elimina ogni residuo di acqua!

Le pompe ad immersione della gamma AR Blue Clean spostano grandi quantità di acqua in poco tempo, fino a 16000 litri all'ora. Le pompe possono essere utilizzate per trasportare acqua pulita o sporca. Il design innovativo consente all'utente di rimuovere l'acqua lasciando solo 5mm di acqua residua sulla superficie piana. Il caratteristico interruttore a galleggiante consente di avviare automaticamente le pompe quando necessario.

Get rid of any water residue!

Annovi Reverberi submersible pumps move large volumes of water in a short time, up to 16000 liters per hour. They can be used to pump out clean or dirty water. The innovative design allows the user to remove the water leaving only 5mm of residual water on the flat surface. The characteristic float switch allows the pumps to be started automatically whenever necessary.



G 1" 1/2 - 38 mm
G 1" - 25 mm
Ø 1" - 25 mm
Ø 1" 1/4 - 32 mm

galleggiante con sistema
di accensione/spegnimento
float with ON/OFF system

acque pulite
clean water

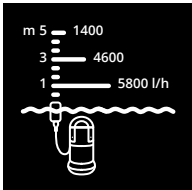

Caratteristiche Generali

- Motore a basso consumo
- Interruttore a galleggiante integrato
- 5 mm min. di livello di aspirazione
- Protezione motore dalle alte temperature

General Features

- Low consumption motor
- Integrated float switch
- 5mm minimum suction level
- Motor protection at high temperatures



MOD	COD					
		V	Hz	W	m	l/h
PS6000PC	52050	230~	50	250	6	6000

Accessori opzionali Optional accessories



46490
(7 m)

T(Max)	IP X	kg
35°C	8	3,7



PS11000XC

POMPE AD IMMERSIONE
submersible pumps

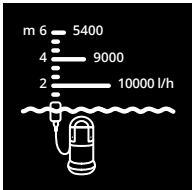
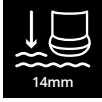
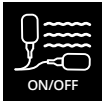
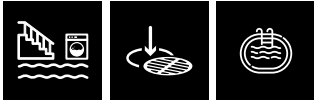

G 1" - 25 mm
 Ø 1" - 25 mm
 Ø 1" 1/4 - 32 mm

acque pulite
 clean water



galleggiante con sistema
 di accensione/spengimento
 float with ON/OFF system

Caratteristiche Generali

- Design compatto
- Corpo in acciaio inox resistente alla corrosione
- Protezione motore dalle alte temperature

General Features

- Compact design
- Corrosion-resistant stainless steel body
- Motor protection at high temperatures



MOD	COD					
		V	Hz	W	m	l/h
PS11000XC	52052	230~	50	750	8,5	11000

T(Max)	IP X	kg
35°C	8	5

Accessori opzionali Optional accessories



46490
 (7 m)

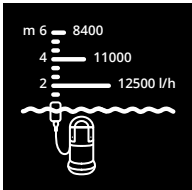
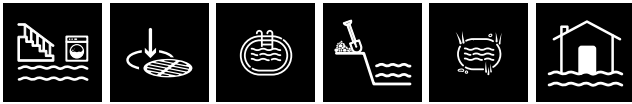

G 1" 1/2 - 38 mm
G 1" - 25 mm
Ø 1" - 25 mm
Ø 1" 1/4 - 32 mm

altezza variabile
per il passaggio
di acqua pulita/sporca
*variable height for passage
of clean/dirty water*



galleggiante con sistema
di accensione/spengimento
float with ON/OFF system

Caratteristiche Generali

- Interruttore a galleggiante integrato
- Piedi pieghevoli per variare l'aspirazione da acque chiare a scure
- Protezione motore dalle alte temperature

General Features

- *Integrated float switch*
- *Folding legs to swith from clean to dirty water suction*
- *Motor protection at high temperatures*

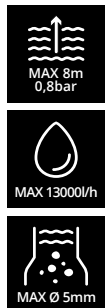

MOD	COD					
		V	Hz	W	m	l/h
PS13000PT	52051	230~	50	750	8	13000

T(Max)	IP X	kg
35°C	8	5,2

Accessori opzionali *Optional accessories*



46490
(7 m)

Sistema multifunzione.

Multifunction system.

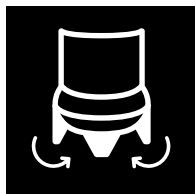

MODALITÀ ACQUA SPORCA

Aperto i piedi della pompa si ha la possibilità di drenare acque molto sporche con residui di diametro fino a 30 mm.

DIRTY WATER MODE

Unfolding the pump feet you can drain very dirty water with residues up to 30mm in diameter.

MODALITÀ ACQUA PULITA

Con i piedi chiusi la pompa consente il drenaggio di acqua pulita lasciando un residuo di soli 5 mm.

CLEAN WATER MODE

Folding the pump feet allows you the drainage of clean water leaving a residue of only 5 mm.

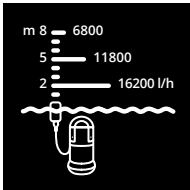

G 1" - 25 mm
Ø 1" - 25 mm
Ø 1" 1/4 - 32 mm



galleggiante con sistema di accensione/spengimento float with ON/OFF system

acque sporche dirty water

Caratteristiche Generali

- Motore performante
- Corpo in acciaio inox resistente alla corrosione
- Protezione motore dalle alte temperature

General Features

- Powerful motor
- Corrosion-resistant stainless steel body
- Motor protection at high temperatures



MOD	COD					
		V	Hz	W	m	l/h
PS16500XD	52053	230~	50	1100	10,5	16500





Accessori opzionali Optional accessories



46490
(7 m)

T(Max)	IP X	kg
35°C	8	6,6



			Autoadescanti <i>Self-priming</i>		Autoadescanti con autoclave <i>Self-priming with booster unit</i>	Immissione <i>Submersible</i>			
			PG3100P	PG4600X	PG3100PB	PS6000PC	PS1100XC	PS13000PT	PS16500XD
Tubo di aspirazione <i>Suction hose</i>		46489 (7 m)	0	0	0				
Tubo di mandata <i>Delivery hose</i>		46490 (7 m)				0	0	0	0
Prefiltro <i>Water filter</i>		46491 (1 l)	0	0					
Prefiltro <i>Water filter</i>		46492 (2 l)			0				

CLEANING DIVISION

DATI LOGISTICI

Logistic data



DATI LOGISTICI

logistic data

Grandezze logistiche/Logistical Data



Mod.	AR code	EAN code	Dimensione scatola	Dimensioni esterne	Q.ty Euro pallet (800x1200 mm)	Container		Camion Full Truck	Peso Weight
			Box dimensions	Outer dimensions		20 ft	40 ft		
			(L x W x H) mm	(L x W x H) mm	n°	n°	n°	n°	Kg
EASY	14299	8016287142991	365x230x370	270x280x670	50*	898	1798	1650	6,7
2LT	15548	8016287155489	315x283x500	280x253x705	16*	420	840	528	11
4LT	15549	8016287155496	590X375X580	280x240x650	12*	228~	468~	396	20
5LT	15550	8016287155502	590X375X580	280x240x650	12*	228~	468~	396	20,5
2K X-TRA	14992	8016287149921	360x340x815	330x307x790	12*	288~	576~	396	13,1
2KA	15149	8016287151491	360x340x815	330x307x790	12*	288~	576~	396	13,8
4K	14823	8016287148238	420x395x770	449x388x895	10*	210~	435~	330	16,7
5K	14950	8016287149501	420x395x770	449x388x895	10*	210~	435~	330	17,3
5SP	15559	8016287155595	420x395x770	449x388x895	10*	210~	435~	330	27,2
SPARK 70	15344	8016287153447	507x267x330	380x239x260	24*	665~	1393~	792	19,4
SPARK 72	15054	8016287150545	507x267x330	380x239x260	24*	665~	1393~	792	22
R.613	14305	8016287143059	300x500x420	460x280x260	24*	264	576	792	20,3
R.613K	14306	8016287143066	487x495x600	460x450x510	12	120	252	312	29,2
R.614	14307	8016287143073	300x500x420	460x280x260	24*	264	576	792	23
R.614K	14308	8016287143080	487x495x600	460x450x510	12	120	252	312	31,7
B.1510	15588	8016287155885	300*500*360	420x310x260	24*	264	576	782	29
RS 1510	22670-V	8016287226707	800*400*580	390*380*900	9	99	225	297	41
RS 1815	22671-V	8016287226714	800*400*580	390*380*900	9	99	225	297	43
MODENA 930	14736	8016287147361	705x540x720	800x480x980	4*	66	138	132	50
MODENA 960	15547	8016287155472	705x540x720	800x480x980	4*	66	138	132	52
MODENA 980	15546	8016287155465	705x540x720	800x480x980	4*	66	138	132	62
1003	24385-V	8016287243858	725*490*770	670*490*900	4*	60	120	132	40,6
1003 RLW	24389-V	8016287243896	725*490*770	670*490*900	4*	60	120	132	53
1005	15602	8016287156028	725*490*770	670*490*900	4*	60	120	132	51,9
1007	15477-V	8016287154772	725*490*770	670*490*900	4*	60	120	132	54,8
1009	15590	8016287155908	725*490*770	670*490*900	4*	60	120	132	67,5
1015	25283-V	8016287252836	600x860x630	580x1020x830	6	66	150	198	77
1018	24491-V	80162872244916	600x860x630	580x1020x830	6	66	150	198	88
1018H	25272-V	80162872252720	600x860x630	580x1020x830	6	66	150	198	88
1120	22374-V	8016287223744	730x1130x760	650x1250x900	2	22	50	66	118
SUPREME 40	27750	8016287277501	520x690x565	771x458x926	6*	140~	296~	198	35,8
SUPREME 43	27752	8016287277525	520x690x565	771x458x926	6*	140~	296~	198	39,1
SUPREME 50	27751	8016287277518	520x690x565	771x458x926	6*	140~	296~	198	39,1
SUPREME 75	27755	8016287277556	830x595x640	900x530x900	*6	75~	153~	198	69,1
SUPREME 90	27754	8016287277549	830x595x690	900x530x900	6*	75~	153~	198	72

~ Floor loaded / sfuso
*Europallet







Grandezze logistiche/Logistical Data

Mod.	AR code	EAN code							
			Dimensione scatola Box dimensions	Dimensioni esterne Outer dimensions	Q.ty Euro pallet (800x1200 mm)	Container		Camion Full Truck	Peso Weight
			(L x W x H) mm	(L x W x H) mm	n°	20 ft	40 ft	n°	Kg
1507	26412-V	8016287264129	510*770*700	500*730*920	6	99	207	198	53
1608	26413-V	8016287264136	487*495*600	510*770*700	6	99	207	198	54
1608 PRO	26415-V	8016287264150	570*780*850	540*800*750	4	44	100	132	88
1510N	15364	8016287153645	790*560*545	540*800*750	4	44	100	132	94
1815	15365	8016287153652	740x1140x1100	540x800x750	1	30	64	72	138
1815N	24400-V	8016287244008	1060*740*960	980*590*920	2	22	50	66	138
2315	24401-V	8016287244015	1060*740*960	980*590*920	2	22	50	66	145
2321	23941	8016287239417	1140x740x1140	1100x700x1040	1	30	64	72	173
1310	24894-V	8016287248945	730*1130*760	1100x650x700	2	22	50	66	103
1320	25273-V	8016287252737	730*1130*760	1100*650*700	2	22	50	66	103
1325	25274-V	8016287252744	730*1130*760	1100*650*700	2	22	50	66	103
1380	25284-V	8016287252843	760*1160*1030	1100*650*700	1	30	60	68	174

Grandezze logistiche/Logistical Data

Mod.	AR code	EAN code							
			Dimensione scatola Box dimensions	Dimensioni esterne Outer dimensions	Q.ty Euro pallet (800x1200 mm)	Container		Camion Full Truck	Peso Weight
			(L x W x H) mm	(L x W x H) mm	n°	20 ft	40 ft	n°	Kg
WD15	51934-V	8016287519342	380x355x405	346x339x385	30*	552~	1140~	990	6,3
WD25	51935-V	8016287519359	380x355x610	346x339x562	18*	354~	738~	594	6,7
30X	52085-V	8016287520850	380x380x580	346x346x578	18*	359~	720~	594	8,1
WD35T	52086-V	8016287520867	475x450x570	465x444x560	6*	220~	460~	198	11,3
WD50XT	52087-V	8016287520874	625x575x645	538x683x852	6*	108~	228~	198	17,6
WD76/2	52586	8016287525862	570x570x1010	530x565x970	8	88	200	264	26
WD76/3	52587	8016287525879	570x570x1010	530x565x970	8	88	200	264	27,5
AR20M	52014	8016287520140	410x410x485	315x315x390	24*	339	688	792	3,8

Grandezze logistiche/Logistical Data

Mod.	AR code	EAN code							
			Dimensione scatola <i>Box dimensions</i>	Dimensioni esterne <i>Outer dimensions</i>	Q.ty Euro pallet (800x1200 mm)	Container		Camion Full Truck	Peso Weight
			(L x W x H) mm	(L x W x H) mm	n°	20 ft	40 ft	n°	Kg
PG3100P	52054	8016287520546	220x180x385	187x167x382	80*	1588~	3264~	*	7,2
PG4600X	52056	8016287520560	410x250x280	380x220x225	49*	1030~	2115~	*	10,4
PG3100PB	52055	8016287520553	485x300x550	440x270x510	18*	350~	730~	*	11,8
PS6000PC	52050	8016287520508	220x160x330	165x158x305	100*	1864~	3436~	*	4,4
PS11000XC	52052	8016287520522	220x180x340	150x150x312	80*	1864~	3436~	*	5,6
PS13000PT	52051	8016287520515	220x160x360	167x160x357	100*	1672~	3432~	*	5,8
PS16500XD	52053	8016287520539	220x180x385	187x167x382	64*	1588~	3264~	*	7,2



Applicazioni Idropultrici Home & Garden *Home & Garden high pressure washers Applications*

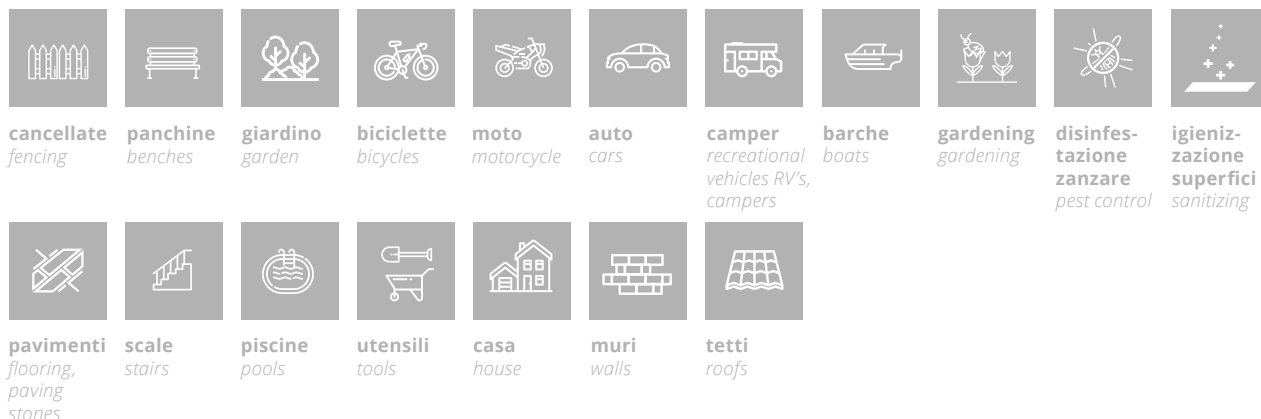

Applicazioni Aspiratori Home & Garden *Home & Garden Vacuums Applications*



Applicazioni Idropultrici/Aspiratori Professionali *Professional High pressure washers/Vacuums Applications*



Applicazioni Pompe autoadescanti ed ad immersione *Water Pumps Applications*



Il presente catalogo annulla e sostituisce tutti i precedenti, può essere modificato senza alcun preavviso. La Annovi Reverberi S.p.A. si riserva la facoltà di effettuare consegne parziali. Dati, descrizioni ed illustrazioni sono forniti a titolo indicativo e non impegnativo. La validità della garanzia è regolamentata dalle normative vigenti nel paese in cui il prodotto viene commercializzato.

This catalogue cancels all previous ones and can be modified without notice. Annovi Reverberi S.p.A. preserves the right to carry out partial shipments. Characteristics and descriptions are not binding. The validity of the Warranty is in accordance with the relevant legislation in the country where the product is sold.

Tecniche *Technical*

pressione massima <i>max pressure</i>	portata massima <i>max flow rate</i>	potenza assorbita <i>absorbed power</i>	peso netto <i>net weight</i>	n° motori <i>engines n°</i>	stadi motore <i>engine stages</i>	depressione <i>vacuum pressure</i>	aria aspirata <i>air flow rate</i>	rumorosità <i>loudness</i>	capacità fusto <i>capacity</i>	diametro accessori <i>accessory diameter</i>
pressione massima <i>max pressure</i>	portata massima <i>max flow</i>	dimensioni di montaggio <i>fitting dimensions</i>	ON/OFF automatico <i>automatic ON/OFF</i>	sistema di scarico <i>drain system</i>	facile riempimento <i>easy fill</i>	impugnatura ergonomica <i>handle</i>	montaggio da tavolo <i>table mounting</i>	serbatoio <i>tank</i>	ON/OFF automatico <i>automatic ON/OFF</i>	acqua residua <i>residual water</i>
dimensione massima particolato <i>max grain size</i>	altezza variabile <i>variable height</i>	corpo in acciaio inossidabile <i>stainless steel body</i>	testata pompa in acciaio inossidabile <i>stainless steel pump head</i>	adatto ad acque pulite <i>suitable for clean water</i>	adatto ad acque sporche <i>suitable for dirty water</i>					

Pompa e motore *Pump & motor*

motore universale <i>universal engine</i>	motore induzione <i>induction engine</i>	motore benzina <i>gasoline engine</i>	pompa a piattello <i>wobble plate pump</i>	pompa a bielle <i>rod-crank pump</i>	testa in ottone <i>brass head</i>	testa in alluminio <i>aluminum head</i>	testa nichelata <i>nichel plated head</i>	temperatura massima <i>max temperature</i>	resistenza all'acqua <i>water resistance</i>	giunto elastico <i>elastic joint</i>
sistema arresto completo <i>total stop system</i>	sistema arresto completo temporizzato <i>total stop system timed</i>	funzine autodecandente <i>self priming function</i>	sistema doppia velocità <i>dual speed system</i>	sistema doppia funzione <i>dual function system</i>	sistema doppia potenza <i>dual power system</i>	sistema doppia applicazione <i>dual appliance system</i>				

Funzioni aspiratori *Vacuum functions*

aspirazione liquidi <i>liquid suction</i>	aspirazione polveri <i>dust suction</i>	funzione soffiante <i>blow function</i>	aspirazione cenere <i>ash suction</i>	presa elettrotensile <i>power tool socket suction</i>

Generiche *Generic*

plug&play <i>plug&play</i>	novità <i>new</i>	acqua fredda <i>cold water</i>	acqua calda <i>hot water</i>	washing performance power <i>prestazioni lavaggio</i>	risparmio tempo <i>time savings</i>	altezza raggiungibile <i>reachable height</i>

Logistiche *Logistic*

euro pallet <i>euro pallet</i>	full track <i>full truck</i>	container	container	dimensioni packaging <i>dimension packaging</i>	dimensioni macchina <i>dimension machine</i>	dimensioni macchina <i>dimension machine</i>	peso lordo <i>gross weight</i>



ANNovi®
REVERBERI

The Power of Experience

Seguici su / Follow us on



Annovi Reverberi spa

Via Martin L. King 3
41122 Modena (Italy)
Tel +39 059 414 411
Fax +39 059 253 505
infoar@annovireverberi.it
www.annovireverberi.it

AR North America Inc.

140 - 81st Avenue Northeast
Fridley, MN USA 55432
Ph. +1 763 398 2008
Fax +1 763 398 2009
info@arnorthamerica.com
www.arnorthamerica.com

AR China Distribution Co., Ltd

2nd Floor, Building 1, No. 651 Jiangting Rd.
Jinhui Town, Fengxian District, Shanghai
201404 China
Ph. +86 21 54846800
Fax +86 21 54846800 ext 815
info@ar-china.cn
www.ar-china.cn